

Industrial Motors

Commercial &
Appliance Motors

Automation

Digital &
Systems

Energy

Transmission &
Distribution

Coatings

DWB Molded Case Circuit Breakers

The **right** molded
case circuit
breaker for your
application



Driving efficiency and sustainability



S U M M A R Y

Presentation	04
General characteristics	08
Protections and settings	11
Accessories	15
Internal accessories	22
External accessories	24
Installation	30
Deratings	33
Thermal dissipation	34
Characteristic curves - I x t	35
Short circuit limiting characteristic curve	41
Dimensions	43
Circuit breaker list - reference and code	61



CE

1234567890



On
L

D
Off

DWB1000H

Ue (V)	Icu/Ics (kA)
240 ~	80/40
380 ~	65/35
415 ~	65/35
440 ~	50/35

15331 VDA cat. A



TEST

Terminal block with five screw terminals. Each terminal has a red cross symbol and a label below it: L, S, S, I, and I. The terminals are arranged in a row. Below the terminals, there are two percentage markings: 70% and 105%.



THE RIGHT MOLDED CASE CIRCUIT BREAKER FOR YOUR APPLICATION

Suitable for industrial, commercial and building applications, the ***new version of the DWB line of WEG molded case circuit breakers*** was ***designed and manufactured according to IEC 60947-1 and IEC 60947-2***, meeting the operation and protection needs of distribution circuits up to 1,600 A.

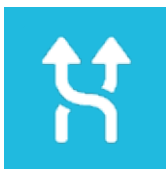

FLEXIBILITY

DWB circuit breakers allow flexibility in the use of internal accessories. Interchangeability of accessories among circuit breakers from 160 A to 1,000 A.



DOUBLE PROTECTION

In order to provide greater safety for the operator, DW circuit breakers have double insulation between live parts (except for the terminals) and the front parts of the equipment. The internal accessories are completely separate from the power circuit, avoiding any risks of contact with the live parts.



HIGH PERFORMANCE

DWB molded case circuit breakers can be used in a wide range of applications with great performance under severe overload and short circuit conditions. When installed in motor circuits combined with WEG contactors (CWB and CWM) and WEG smart relays (SRW), they comply with coordination 2 requirements as per IEC 60947-4-1.



The right circuit breaker for your application

The models are available with three types of protection - **thermomagnetic, magnetic and with electronic protection type LSI** specific for each type of load.

For **distribution circuits in general up to 800 A**, the circuit breakers with Thermomagnetic element provide enough overload and short circuit protection for both AC and DC applications, allowing the economic and safe assembly of distribution systems.

For **distribution circuits from 500 A to 1,600 A**, circuit breakers with Electronic LSI protection provide optimization of the protection circuits and higher operation accuracy by means of the following protections:

- Protection against overload (“L” = Long time delay trip)
- Short-time delay trip for protection against short-circuit (“S” = short-time delay), allowing selective action in case of shortcircuit currents
- Instantaneous short-circuit protection (“I” = Instantaneous)

In applications where it is necessary **to switch and protect motor circuits**, DWB circuit breakers up to 1,000 A have magnetic protection relays especially adjusted for this type of load, ensuring their correct operation in case of short-circuit currents. Circuit breakers with magnetic protection for motor circuits must be combined with other switching and protection elements, such as contactors and overload relays (thermal or electronic). For **switching and protecting generators**, the models are also manufactured with protective relays specially adjusted for this type of load.



Protecting and disconnecting in 5 frames

Available in 5 sizes from 16 A to 1,600 A, according to the maximum rated current of each size (frame):

- DWB160 - maximum rated current of 160 A
- DWB250 - maximum rated current of 250 A
- DWB400 - maximum rated current of 400 A
- DWB800 and DWB1000¹⁾ - maximum rated current of 800 A and 1,000 A respectively
- DWB1600¹⁾ - maximum rated current of 1,600 A

Manufactured with quality raw materials, the molded-case circuit breakers of the DWB line ensure high performance for different applications.

- Frame made of SMC (Sheet Molding Compound): in addition to high mechanical performance, it also presents high dielectric strength and withstands high temperatures
- Fixed and moving contacts made with special metal alloys to ensure safe operation and long service life
- Electrolytic copper terminals with surface treatment (silver-coated terminals) ensuring protection against corrosion and excessive heating of the connections
- Front cover made of polycarbonate (DWB circuit breakers) providing greater safety for the applications

The special laser engraving system used on DWB circuit breakers ensures indelibility of the product information and characteristic along its useful life.



Note: 1) With LSI electronic protection.

General characteristics



Frame			DWB160	DWB250					
Standard			IEC 60947-2						
Number of poles			2 ¹⁾ , 3, 4						
Rated operational voltage	U _e	V ac	690 ⁷⁾						
		V dc	500						
Insulation voltage		V	800						
Rated impulse withstand voltage		U _{imp}	8						
Utilization category		-	A						
Reference temperature		T	45						
Pollution degree		-	3						
Breaking capacity level									
Rated ultimate short-circuit breaking capacity - I _{cu}	I _{cu}	kA	B	N	L ²⁾	B	N	L ²⁾	
		240 V~	25	50	120	40	80	120	
		380 V~	18	30 ³⁾	80	18	36	80	
		415 V~	16	30 ³⁾	80	16	36	80	
		440 V~	10	20 ⁴⁾	80	15	30	80	
		500 V~	5	8	65	5	8	65	
		550 V~	4	6	25	4	7	25	
		690 V~	3	4	10	3	6	15	
		1 pole	125 V dc	35	65	-	35	65	-
		2 poles in series	250 V dc	35	65	-	35	65	-
3 poles in series	500 V dc	25	50	-	25	50	-		
Rated service short-circuit breaking capacity - I _{cs}	I _{cs}	kA	B	N	L ²⁾	B	N	L ²⁾	
		240 V~	25	25	80	40	40	80	
		380 / 400 V~	16	16	60	16	17	60	
		415 V~	16	16	60	16	17	60	
		440 V~	10	10	60	15	15	60	
		500 V~	5	5	50	5	5	50	
		550 V~	4	4	20	4	4	20	
		690 V~	3	3	8	3	3	8	
Type of protection and application⁸⁾¹²⁾									
Thermomagnetic for distribution	Fixed thermal and fixed magnetic	I _n	A	16, 20, 25, 32, 40, 50, 63, 70, 80, 90, 100, 110, 125, 150, 160	16, 20, 25, 32, 40, 50, 63, 70, 80, 90, 100, 110, 125	Not applicable			
	Adjustable thermal and fixed magnetic	I _n	A	40, 50, 63, 80, 100, 125, 160	-	100, 125, 160, 200, 250	100, 125, 160, 200		
	Adjustable thermal and adjustable magnetic	I _n	A	Not applicable		Not applicable			
Thermomagnetic for generator	Fixed thermal and fixed magnetic	I _n	A	Not applicable		Not applicable			
	Adjustable thermal and fixed magnetic	I _n	A	55, 75, 85, 105, 125, 140, 160	Not applicable	105, 125, 160, 200, 250	Not applicable		
	Adjustable thermal and adjustable magnetic	I _n	A	Not applicable		Not applicable			
Magnetic for motor	Fixed magnetic	I _n	A	Not applicable	25, 32, 40, 50, 65, 80, 95	Not applicable	80, 105, 150, 185, 200		
	Adjustable magnetic	I _n	A	Not applicable		Not applicable			
Electronic (LSI) for distribution and generator ¹⁵⁾			A	Not applicable		Not applicable			
Mechanical lifespan - C-0 cycle			Number of operations/operations per hour	8,000 / 120		8,000 / 120			
Electrical lifespan - C-0 cycle (I _n @ 690 V)			Number of operations/operations per hour	1,000 / 120		1,000 / 120			
Degree of protection			Terminals	IP10		IP10			
			Accessory cover	IP20		IP20			
Maximum air relative humidity				95%		95%			
Connection with cable ¹¹⁾¹³⁾	Recommended	mm ²	See the Connection to Terminals section			See the Connection to Terminals section			
	Tightening torque	Nm	6			25 ⁵⁾			
Connection with bar	Recommended cross section (width x thickness)	mm x mm	See the Connection to Terminals section			See the Connection to Terminals section			
	Tightening torque	Nm	6			8			
Resistance to vibration (IEC 60068-2-6)			2 to 13.2 Hz: amplitude ±1 mm 13.2 to 100 Hz: constant of acceleration 0.7 g			2 to 13.2 Hz: amplitude ±1 mm 13.2 to 100 Hz: constant of acceleration 0.7 g			
Resistance to mechanical shocks (IEC 60068-2-27 - 1/2 sine)			12 g for 11ms			12 g for 11ms			
Dimensions (Width x Depth x Height)		mm x mm x mm	2 poles: 78 x 71 x 122 3 poles: 78 x 71 x 122 4 poles: 102.5 x 71 x 122	3 poles: 78 x 136 x 143	2 poles: 105 x 78 x 162 3 poles: 105 x 78 x 162 4 poles: 141 x 75 x 162	3 poles: 105 x 137 x 191			
Net weight		kg	2 poles: 0.79 / 3 poles: 0.9 / 4 poles: 1.24	3 poles: 1.84	2 poles: 1.42 / 3 poles: 1.85 / 4 poles: 2.5	3 poles: 3.75			

Notes: 1) 2 poles on the 3-pole frame. Available only for DWB160B with fixed trigger, DWB250B, DWB250N, DWB400N and DWB400H.

2) Only available on 3-pole frame; not available with protection for generator.

3) For I_n ≤ 32 A: I_{cu} = 20 kA @ 380 V / 415 V.

4) For I_n ≤ 32 A: I_{cs} = 15 kA @ 440 V.

5) Recommended torque for the terminal lugs accessory - PC (sold separately). If lug terminal is used directly on the circuit breaker terminal, consider the recommended torque for connection with bar.

6) Product height without terminal cover.

7) For applications above 2000 m of altitude, consider the derating indicated in the table of page 31.

8) I_n = rated current (fixed thermal release) or maximum setting value (adjustable thermal release).

General characteristics



DWB400		DWB800		DWB1000		DWB1600	
IEC 60947-2		IEC 60947-2		IEC 60947-2		IEC 60947-2	
2 ¹⁾ , 3, 4 ¹⁴⁾		3, 4 ¹⁴⁾		3, 4		3, 4	
690 ⁷⁾		690 ⁷⁾		690 ⁷⁾		500 ⁷⁾	
500		500		500		-	
800		800		800		690	
8		8		8		8	
A		A		A		A	
45		45		45		45	
3		3		3		3	
N	H	N	S	H	S	H	N
40	80	40	65	80	65	80	80
35	65	35	50	65	50	65	35
35	50	35	50	65	50	65	35
35	50	35	42	50	42	50	25
20	25	20	22	25	22	25	20
10	15	10	12	15	12	15	-
8	10	8	8	10	8	10	-
35	65	35	50	65	-	-	-
35	65	35	50	65	-	-	-
25	50	25	35	50	-	-	-
N	H	N	S	H	S	H	N
40	40	40	40	40	40	40	40
35	35	35	35	35	35	35	25
35	35	35	35	35	35	35	25
25	25	35	35	35	35	35	25
12	12	20	20	20	20	20	20
10	10	10	10	10	10	10	-
8	8	8	8	8	8	8	-
Not applicable		Not applicable		Not applicable		Not applicable	
Not applicable		Not applicable		Not applicable		Not applicable	
200, 250, 320, 400		Not applicable	320, 400, 500, 630, 800		Not applicable		Not applicable
Not applicable		Not applicable		Not applicable		Not applicable	
Not applicable		Not applicable		Not applicable		Not applicable	
200, 250, 320, 400	Not applicable	630, 800	Not applicable		Not applicable		Not applicable
Not applicable		Not applicable		Not applicable		Not applicable	
Not applicable	150, 185, 250, 320	Not applicable		420, 500		Not applicable	
Not applicable		Not applicable		500, 630, 800, 1,000		1,250, 1,600	
5,000 / 120		3,000 / 60		3,000 / 60		3,000 / 60	
1,000 / 120		I _n ≤630 A: 1,000 / 120 I _n =800 A: 500 / 60		I _n =1,000 A: 500 / 60		500 / 60	
IP10		IP10		IP10		IP10	
IP20		IP20		IP20		IP20	
95%		95%		95%		95%	
See the connection to terminals section		See the connection to terminals section		See the connection to terminals section		See the connection to terminals section	
30 ⁹⁾		50 ⁹⁾		55 ⁹⁾		55 ⁹⁾	
See the connection to terminals section		See the connection to terminals section		See the connection to terminals section		See the connection to terminals section	
20		20		20		30 (M10) / 50 (M12)	
2 to 13.2 Hz: amplitude ±1 mm 13.2 to 100 Hz: constant of acceleration 0.7 g		2 to 13.2 Hz: amplitude ±1 mm 13.2 to 100 Hz: constant of acceleration 0.7 g		2 to 13.2 Hz: amplitude ±1 mm 13.2 to 100 Hz: constant of acceleration 0.7 g		2 to 13.2 Hz: amplitude ±1 mm 13.2 to 100 Hz: constant of acceleration 0.7 g	
12 g for 11ms		12 g for 11ms		12 g for 11ms		12 g for 11ms	
3 poles: 107 x 99 x 256 4 poles: 141 x 99 x 256		3 poles: 210 x 99 x 256 ⁹⁾ 4 poles: 280 x 99 x 256 ⁹⁾		3 poles: 210 x 99 x 256 ⁹⁾ 4 poles: 280 x 99 x 256 ⁹⁾		3 poles: 210 x 146 x 345 ⁹⁾ 4 poles: 280 x 146 x 345 ⁹⁾	
3 poles: 3.56 / 4 poles: 4.6		3 poles: 7.4 / 4 poles: 9.2		3 poles: 7.4 / 4 poles: 9.2		3 poles: 16.4 / 4 poles: 19.9	

- 9) Information on thermal dissipation of the circuit breakers available on page 32.
 10) Thermal and magnetic operation range available on the Time x Current characteristic curves.
 11) See the Installation section. "Connection of cables and bars to terminals", "Direct connection of cables by means of round terminal lugs" and "Direct connection of bar to circuit breaker" tables.
 12) For ambient temperature different from 45 °C, consider the deratings of the "Temperature Derating" Table.
 13) It is recommended to use terminal lugs accessories - PC (optional accessory for the circuit breakers, except for DWB160, which is supplied with terminal lugs) or BE straight extension bar.
 14) DWB160 and DWB250 circuit breakers are available in the four-pole versions with protection on the four poles and 3P+N version with protection on three poles and disconnection on the fourth pole. DWB400 and DWB800 circuit breakers are available in the four-pole versions with protections on three poles and disconnection on the fourth pole.
 15) For definite-time trips (I²t OFF), the opening times of the trip mechanisms must be added to the trip times, where, respectively, for the DWB1600 circuit-breaker equal to 70 ±20ms and for the DWB1000 circuit-breaker equal to 50 ±20ms.

General characteristics

Coding

DWB160 B 125 - 3 DF

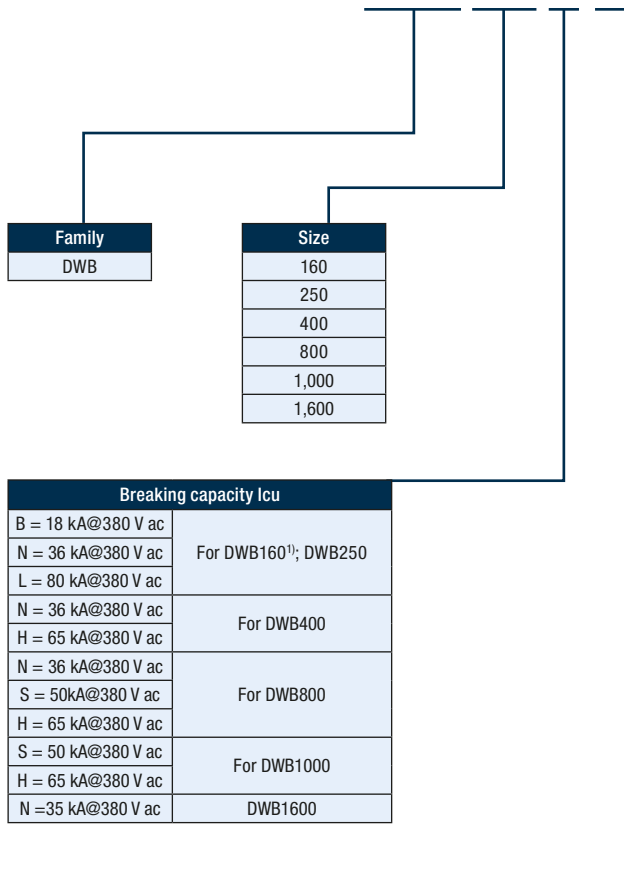

Family
DWB

Size
160
250
400
800
1,000
1,600

Breaking capacity Icu	
B = 18 kA@380 V ac	For DWB160 ¹⁾ ; DWB250
N = 36 kA@380 V ac	
L = 80 kA@380 V ac	
N = 36 kA@380 V ac	For DWB400
H = 65 kA@380 V ac	
N = 36 kA@380 V ac	For DWB800
S = 50kA@380 V ac	
H = 65 kA@380 V ac	
S = 50 kA@380 V ac	For DWB1000
H = 65 kA@380 V ac	
N =35 kA@380 V ac	DWB1600

Rated current	
16, 20, 25, 32, 40, 50, 63, 70, 80, 90, 100, 110, 125,150, 160	For DWB160(B or N)-_DX
16, 20, 25, 32, 40, 50, 63, 70, 80, 90, 100, 110, 125	For DWB160L-_DX
40, 50, 63, 80, 100, 125, 160	For DWB160__-_DF
55, 75, 85, 105, 125, 140, 160	For DWB160__-_GX
25, 32, 40, 50, 65, 80, 95	For DWB160(N or L)-_MF
100, 125, 160, 200, 250	For DWB250B or N-_DF
100, 125, 160, 200	For DWB250L-_DF
100, 125, 160, 200, 250	For DWB250B-_GF
80, 105, 150, 185, 200	For DWB250B-_MF
200, 250, 320, 400	For DWB400__-_DA
200, 250, 320, 400	For DWB400N-_GA
150, 185, 250, 320	For DWB400H-_MA
320, 400, 500, 630, 800	For DWB800__-_DA
320, 400, 500, 630, 800	For DWB800N-_GA
420, 500	For DWB800H-_MA
500, 630, 800, 1,000	DWB1000__-_ET__
1,250, 1,600	DWB1600__-_ET__
1,000	DWB1600N-_MA

Note: 1) DWB160 "N" breaking capacity Icu = 30 kA@380 V ac.

Protection type		
DX	Distribution - Fixed Thermal / Fixed Magnetic	For DWB160B or N
DF	Distribution - Adjustable Thermal / Fixed Magnetic	For DWB160 and DWB250
DA	Distribution - Adjustable Thermal / Adjustable Magnetic	For DWB400; DWB800
GX	Generator - Fixed Thermal / Fixed Magnetic	For DWB160B
GF	Generator - Adjustable Thermal / Fixed Magnetic	For DWB250B
GA	Generator - Adjustable Thermal / Adjustable Magnetic	For DWB400N and DWB800N
MF	Motor - Fixed Magnetic	For DWB160N or L; DWB250N or L
MA	Motor - Adjustable Magnetic	DWB400H; DWB800H; DWB1600N
ET	Electronics - LSI (3 Phases)	DWB1000 and DWB1600
ETA	Electronics - LSI (3 Phases + N)	

Number of poles	
2	DWB160B-_DX
	DWB250(B or N)-_DF
	DWB400(N or H)
3	DWB160(B or N or L)-_(DX or DF)
	DWB160B-_GX
	DWB160(N or L)-_MF
	DWB250
	DWB400
	DWB800
4	DWB160(B or N)-_(DX or DF)
	DWB160B-_GF
	DWB250 (B or N)-_DF
	DWB250B-_GA
	DWB400(N or H)
	DWB400N-_GA
	DWB800
	DWB1000
DWB1600	

Protections and settings

Protections

In order to meet the different requirements of the different types of load of an electrical circuit, DWB has special versions for each type of load, as shown below.

- **Circuit breakers for distribution:** thermal and magnetic protection for electric circuits in general; setting of the short circuit protection from 5 to 10 times the circuit breaker rated current, with tripping curve according to the criteria of IEC 60947-2 standard.
- **Circuit breakers for motors:** magnetic protection only. The short circuit tripping curve is set from 7.5 to 15 times the circuit breaker rated current. Such setting allows starting the motor without premature trip of the protection system. It is necessary to add an overcurrent relay for protection against motor overload.
- **Circuit breakers for generators:** the protection against short circuit is set to trip up to five times the circuit breaker rated current, protecting the generator against current surges that may damage its electronics and compromise its regulation.

Setting for circuit breakers (motors)

DWB160 and DWB250



Fixed magnetic protection

- The circuit breaker tripping curve is fixed

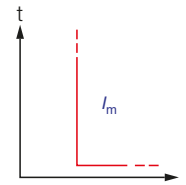

DWB400 and DWB800

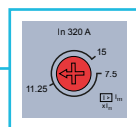

Adjustable magnetic protection

- 7.5 to 15 x I_n for motors

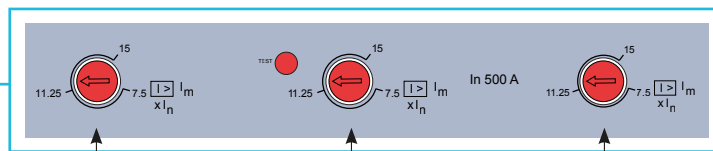
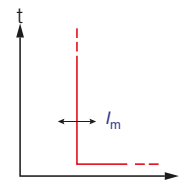

Adjustable magnetic protection per phase

- 7.5 to 15 x I_n for motors

DWB1600

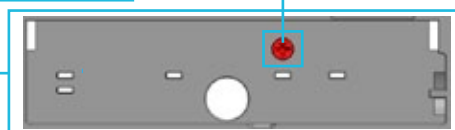
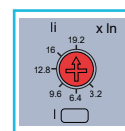
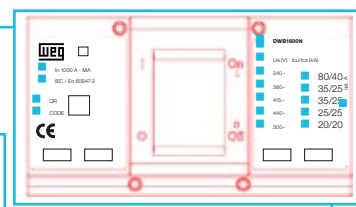

Adjustable magnetic protection

- 3.2 to 19.2 x I_n for motors

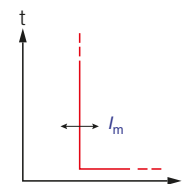

Protections and settings

Settings for circuit breakers (distribution and generators)

DWB160



Fixed thermal and fixed magnetic

- The circuit breaker tripping curve is fixed

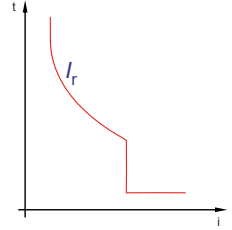

DWB160 and DWB250

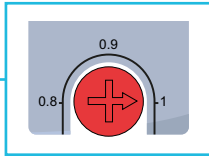

Adjustable thermal and fixed magnetic

- The thermal protection curve allows setting the thermal element from 0.8 to $1 \times I_n$

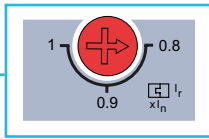
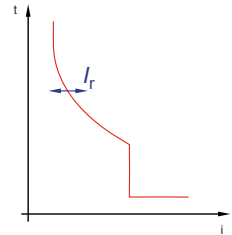

DWB400 and DWB800

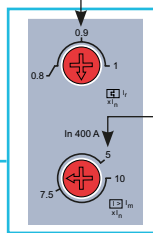

Adjustable thermal protection

- The thermal protection curve allows setting the thermal element from 0.8 to $1 \times I_n$

Adjustable thermal protection

- 5 to $10 \times I_n$ for distribution
- 2.5 to $5 \times I_n$ for generators

Adjustable thermal protection

- The thermal protection curve allows setting the thermal element from 0.7 to $1 \times I_n$

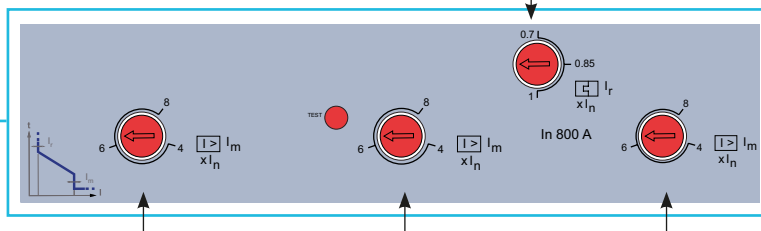

Adjustable magnetic protection per phase¹⁾

- 5 to $10 \times I_n$ for distribution
- 2.5 to $5 \times I_n$ for generators

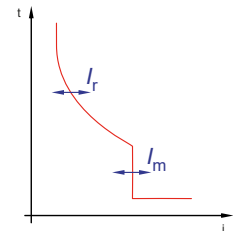

Note: 1) Valid range up to nominal current 630 A. For nominal current 800 A: 4 to $8 \times I_n$ for distribution.

Protections and settings

Settings for circuit breakers (distribution and generators)

DWB1000



■ For DWB1000-1000 A
■ $I_s \text{ max.} = 8$ ■ $I_i \text{ max.} = 10$

Electronic LSI protection

DWB1600-E



Electronic LSI protection

1 2

Long protection (L)

Setting of the rated current and time delay of the overload protection

3 4

Short protection (S)

Setting of the current and time delay of the short-circuit protection

5

Instantaneous protection (I)

Setting of the instantaneous tripping current

Protections

- **L (Long):** overload protection with reverse time-current curve and adjustable time delay
- **S (Short):** short circuit protection with time delay, having settings of tripping current and response time, and possibility to choose between reverse time-current curve (I^2t ON) or defined time (I^2t OFF)
- **I (Instantaneous):** short circuit protection with setting of the tripping current, without setting of the response time

Indication LEDs

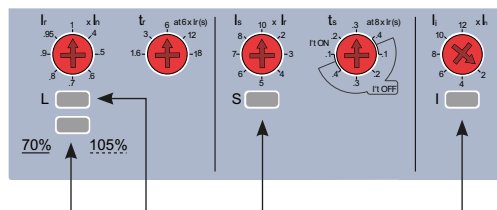

70% / 105%:

- LED ON when 70% of I_n is reached
- LED flashing when 105% of I_n is reached

- When closing the circuit breaker after a trip, one of the LEDs of L, S and I indicates which of the settings commanded the last trip, flashing ten times. After such indication, the LEDs remain OFF

- The electronic protection of the circuit breaker is self-supplied. Thus, the relay will be functional for currents equivalent to $0.2 \times I_n$ for three-phase circuit or $0.35 \times I_n$ for one phase supplied. Under these conditions, the LEDs 70% / 105%, L, S, I (and N - when applicable), light solidly for approximately 1 second, indicating that the electronic protection unit has been self-powered. However, if the current oscillates above and below the self-powered value, the LEDs will stay on and off while the current does not stabilize above the minimum value that guarantees self-feeding.

Note: if the self-feeding current falls below the value, leaving the protection unit de-energised, if there is a short circuit in the feeder, the circuit breaker will act and turn off this feeder. This action is independent of the protection unit.

Protections and settings

Settings for circuit breakers (distribution and generators)

DWB1000

■ For DWB1000-1000 A
 ■ $I_s \text{ max.} = 8$ ■ $I_i \text{ max.} = 10$

Electronic LSI Protection

1: I_r (L) settings: 0.95, 1, 1.5, 2, 3, 4, 6, 8, 10, 12, 15, 18, 20, 25, 30, 35, 40, 45, 50, 60, 70, 80, 90, 100, 120, 150, 180, 200, 250, 300, 350, 400, 450, 500, 600, 700, 800, 900, 1000, 1200, 1500, 1800, 2000, 2500, 3000, 3500, 4000, 4500, 5000, 6000, 7000, 8000, 9000, 10000, 12000, 15000, 18000, 20000, 25000, 30000, 35000, 40000, 45000, 50000, 60000, 70000, 80000, 90000, 100000, 120000, 150000, 180000, 200000, 250000, 300000, 350000, 400000, 450000, 500000, 600000, 700000, 800000, 900000, 1000000. 70% 105%

2: t_r (S) settings: 3, 4, 6, 8, 10, 12, 15, 18, 20, 25, 30, 35, 40, 45, 50, 60, 70, 80, 90, 100, 120, 150, 180, 200, 250, 300, 350, 400, 450, 500, 600, 700, 800, 900, 1000, 1200, 1500, 1800, 2000, 2500, 3000, 3500, 4000, 4500, 5000, 6000, 7000, 8000, 9000, 10000, 12000, 15000, 18000, 20000, 25000, 30000, 35000, 40000, 45000, 50000, 60000, 70000, 80000, 90000, 100000, 120000, 150000, 180000, 200000, 250000, 300000, 350000, 400000, 450000, 500000, 600000, 700000, 800000, 900000, 1000000. at $6 \times I_r$ (s)

3: I_s (S) settings: 8, 10, 12, 15, 18, 20, 25, 30, 35, 40, 45, 50, 60, 70, 80, 90, 100, 120, 150, 180, 200, 250, 300, 350, 400, 450, 500, 600, 700, 800, 900, 1000, 1200, 1500, 1800, 2000, 2500, 3000, 3500, 4000, 4500, 5000, 6000, 7000, 8000, 9000, 10000, 12000, 15000, 18000, 20000, 25000, 30000, 35000, 40000, 45000, 50000, 60000, 70000, 80000, 90000, 100000, 120000, 150000, 180000, 200000, 250000, 300000, 350000, 400000, 450000, 500000, 600000, 700000, 800000, 900000, 1000000. at $8 \times I_r$ (s)

4: t_s (S) settings: 0.1, 0.2, 0.3, 0.4, 0.5, 0.6, 0.8, 1, 1.2, 1.5, 2, 3, 4, 5, 6, 8, 10, 12, 15, 18, 20, 25, 30, 35, 40, 45, 50, 60, 70, 80, 90, 100, 120, 150, 180, 200, 250, 300, 350, 400, 450, 500, 600, 700, 800, 900, 1000, 1200, 1500, 1800, 2000, 2500, 3000, 3500, 4000, 4500, 5000, 6000, 7000, 8000, 9000, 10000, 12000, 15000, 18000, 20000, 25000, 30000, 35000, 40000, 45000, 50000, 60000, 70000, 80000, 90000, 100000, 120000, 150000, 180000, 200000, 250000, 300000, 350000, 400000, 450000, 500000, 600000, 700000, 800000, 900000, 1000000. at $8 \times I_r$ (s)

5: I_i (I) settings: 8, 10, 12, 15, 18, 20, 25, 30, 35, 40, 45, 50, 60, 70, 80, 90, 100, 120, 150, 180, 200, 250, 300, 350, 400, 450, 500, 600, 700, 800, 900, 1000, 1200, 1500, 1800, 2000, 2500, 3000, 3500, 4000, 4500, 5000, 6000, 7000, 8000, 9000, 10000, 12000, 15000, 18000, 20000, 25000, 30000, 35000, 40000, 45000, 50000, 60000, 70000, 80000, 90000, 100000, 120000, 150000, 180000, 200000, 250000, 300000, 350000, 400000, 450000, 500000, 600000, 700000, 800000, 900000, 1000000. at $12 \times I_r$

Neutral protection: 100%, 50%, OFF. $I_{\text{Neutral}} \times I_r$

Protection resulting at the neutral pole			
I_{Neutral}	L	S	I
100%	$I_r \text{ neutral} = I_r$	$I_s \text{ neutral} = I_s$	$I_i \text{ neutral} = I_i$
50%	$I_r \text{ neutral} = 0.5 \times I_r$	$I_s \text{ neutral} = 0.5 \times I_s$	$I_i \text{ neutral} = I_i$
OFF	OFF	OFF	$I_i \text{ neutral} = I_i$

DWB1600-E

Electronic LSI protection

1: I_r (L) settings: 0.95, 1, 1.5, 2, 3, 4, 6, 8, 10, 12, 15, 18, 20, 25, 30, 35, 40, 45, 50, 60, 70, 80, 90, 100, 120, 150, 180, 200, 250, 300, 350, 400, 450, 500, 600, 700, 800, 900, 1000, 1200, 1500, 1800, 2000, 2500, 3000, 3500, 4000, 4500, 5000, 6000, 7000, 8000, 9000, 10000, 12000, 15000, 18000, 20000, 25000, 30000, 35000, 40000, 45000, 50000, 60000, 70000, 80000, 90000, 100000, 120000, 150000, 180000, 200000, 250000, 300000, 350000, 400000, 450000, 500000, 600000, 700000, 800000, 900000, 1000000. 70% 105%

2: t_r (S) settings: 3, 4, 6, 8, 10, 12, 15, 18, 20, 25, 30, 35, 40, 45, 50, 60, 70, 80, 90, 100, 120, 150, 180, 200, 250, 300, 350, 400, 450, 500, 600, 700, 800, 900, 1000, 1200, 1500, 1800, 2000, 2500, 3000, 3500, 4000, 4500, 5000, 6000, 7000, 8000, 9000, 10000, 12000, 15000, 18000, 20000, 25000, 30000, 35000, 40000, 45000, 50000, 60000, 70000, 80000, 90000, 100000, 120000, 150000, 180000, 200000, 250000, 300000, 350000, 400000, 450000, 500000, 600000, 700000, 800000, 900000, 1000000. at $6 \times I_r$ (s)

3: I_s (S) settings: 8, 10, 12, 15, 18, 20, 25, 30, 35, 40, 45, 50, 60, 70, 80, 90, 100, 120, 150, 180, 200, 250, 300, 350, 400, 450, 500, 600, 700, 800, 900, 1000, 1200, 1500, 1800, 2000, 2500, 3000, 3500, 4000, 4500, 5000, 6000, 7000, 8000, 9000, 10000, 12000, 15000, 18000, 20000, 25000, 30000, 35000, 40000, 45000, 50000, 60000, 70000, 80000, 90000, 100000, 120000, 150000, 180000, 200000, 250000, 300000, 350000, 400000, 450000, 500000, 600000, 700000, 800000, 900000, 1000000. at $8 \times I_r$ (s)

4: t_s (S) settings: 0.1, 0.2, 0.3, 0.4, 0.5, 0.6, 0.8, 1, 1.2, 1.5, 2, 3, 4, 5, 6, 8, 10, 12, 15, 18, 20, 25, 30, 35, 40, 45, 50, 60, 70, 80, 90, 100, 120, 150, 180, 200, 250, 300, 350, 400, 450, 500, 600, 700, 800, 900, 1000, 1200, 1500, 1800, 2000, 2500, 3000, 3500, 4000, 4500, 5000, 6000, 7000, 8000, 9000, 10000, 12000, 15000, 18000, 20000, 25000, 30000, 35000, 40000, 45000, 50000, 60000, 70000, 80000, 90000, 100000, 120000, 150000, 180000, 200000, 250000, 300000, 350000, 400000, 450000, 500000, 600000, 700000, 800000, 900000, 1000000. at $8 \times I_r$ (s)

5: I_i (I) settings: 8, 10, 12, 15, 18, 20, 25, 30, 35, 40, 45, 50, 60, 70, 80, 90, 100, 120, 150, 180, 200, 250, 300, 350, 400, 450, 500, 600, 700, 800, 900, 1000, 1200, 1500, 1800, 2000, 2500, 3000, 3500, 4000, 4500, 5000, 6000, 7000, 8000, 9000, 10000, 12000, 15000, 18000, 20000, 25000, 30000, 35000, 40000, 45000, 50000, 60000, 70000, 80000, 90000, 100000, 120000, 150000, 180000, 200000, 250000, 300000, 350000, 400000, 450000, 500000, 600000, 700000, 800000, 900000, 1000000. at $12 \times I_r$

Neutral protection: 100%, 50%, OFF. $I_{\text{Neutral}} \times I_r$

- For LSI protection configuration, see previous page
- For four-pole circuit breakers with adjustable neutral protection, neutral protection can be selected by the 3-position switch, considering the values:
- **100%:** neutral fully protected to I_r
- **50%:** neutral protected with half the phase value. That is: $0.5 \times I_r$ for overload protection I_r (L - long-time) and short-time (S-short) protection. The instantaneous protection configuration I_i (I - instantaneous) for the neutral is equal to the set value
- **OFF:** disables the I_r overload protection (L - long - time) and I_s (short - time) short - circuit protection. The instantaneous protection configuration I_i (I - instantaneous) for the neutral is equal to the setting value

Accessories

Overview - DWB160

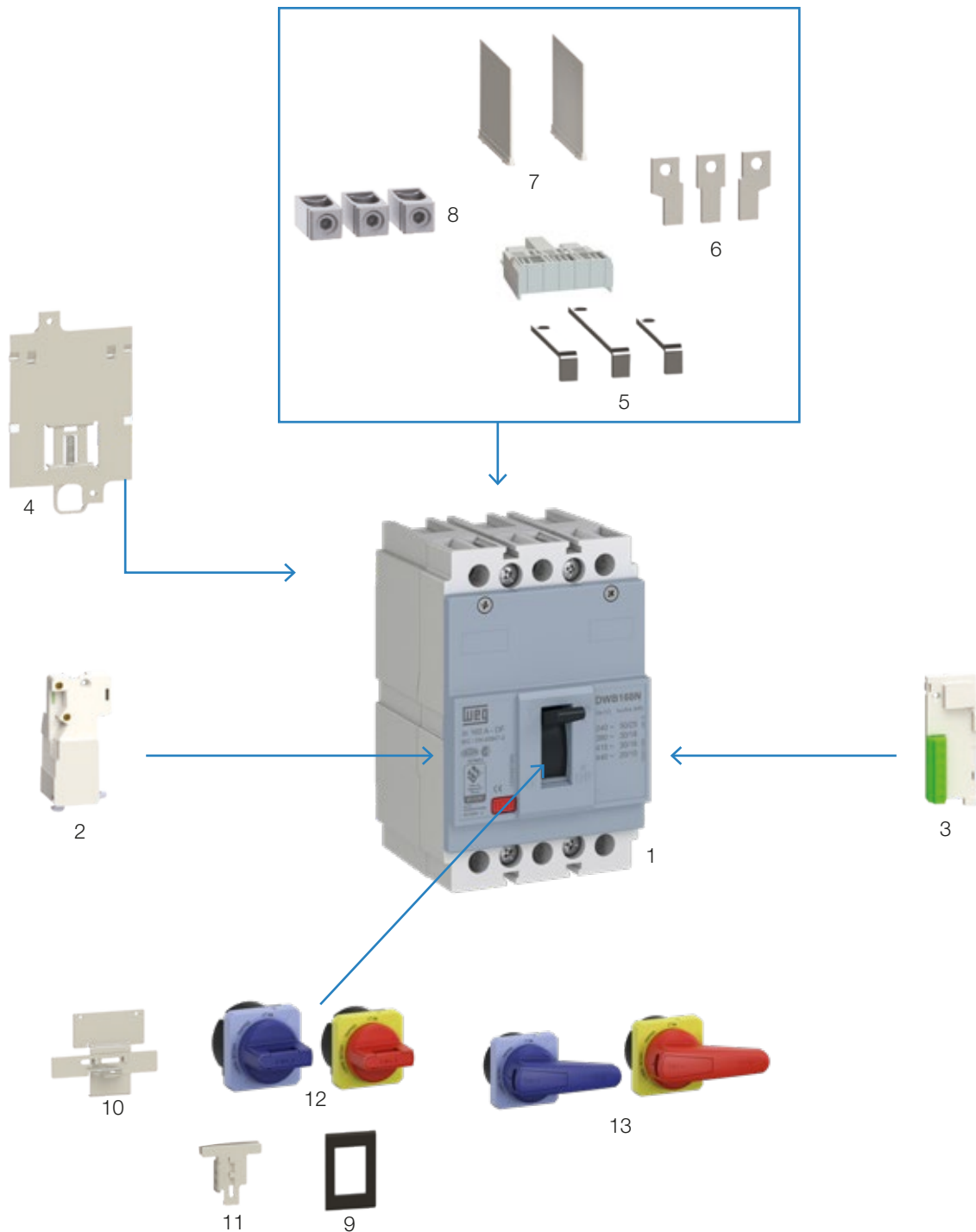

- | | |
|--|--|
| 1 - DWB160 circuit breaker | 7 - PB - phase barrier |
| 2 - BS or BD - undervoltage release or shunt release | 8 - PC - terminal lugs (included in the circuit breaker) |
| 3 - BC - auxiliary contact block | 9 - MP - escutcheon |
| 4 - BFR - DIN rail base | 10 - BLIM - mechanical interlock |
| 5 - CT - 90° connection extension bars (CP 90° connection extension bars protection cover included) (except DWB160L) | 11 - PL - padlocking device |
| 6 - BE - straight extension bar | 12 - MRXS - panel door rotary operating handle |
| | 13 - MRXL - panel door rotary operating handle (length of handle 105 mm) |

Accessories

Overview - DWB250

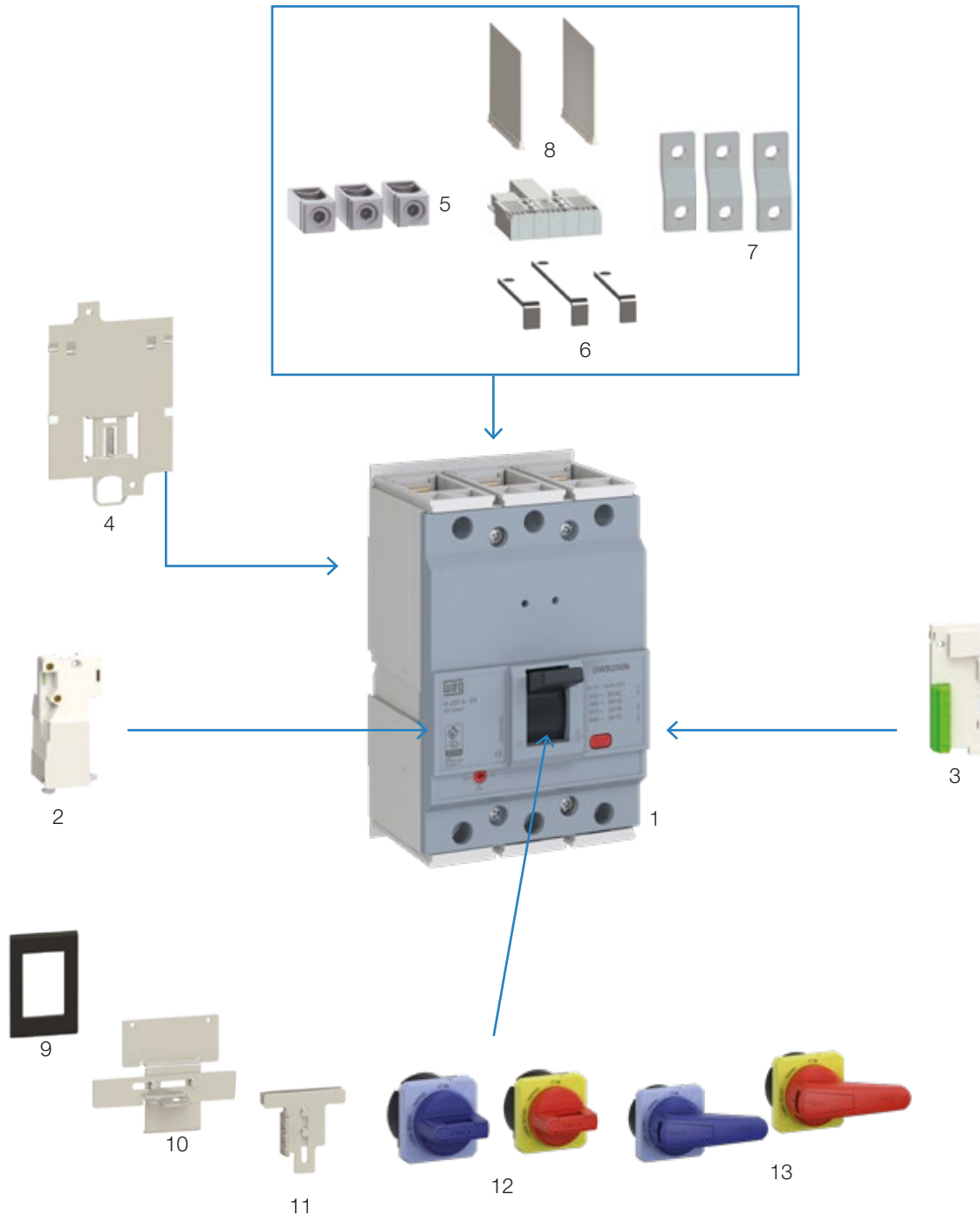

- 1 - DWB250 circuit breaker
- 2 - BS or BD - undervoltage release or shunt release
- 3 - BC - auxiliary contact block
- 4 - BFR - DIN rail base
- 5 - PC - terminal lugs
- 6 - CT - 90° connection extension bars (CP 90° connection extension bars protection cover included) (except DWB250L)

- 7 - BE - straight extension bar
- 8 - PB - phase barrier
- 9 - MP - escutcheon
- 10 - BLIM - mechanical interlock
- 11 - PL - padlocking device
- 12 - MRXS - panel door rotary operating handle
- 13 - MRXL - panel door rotary operating handle (length of handle 105 mm)

Accessories

Overview - DWB400

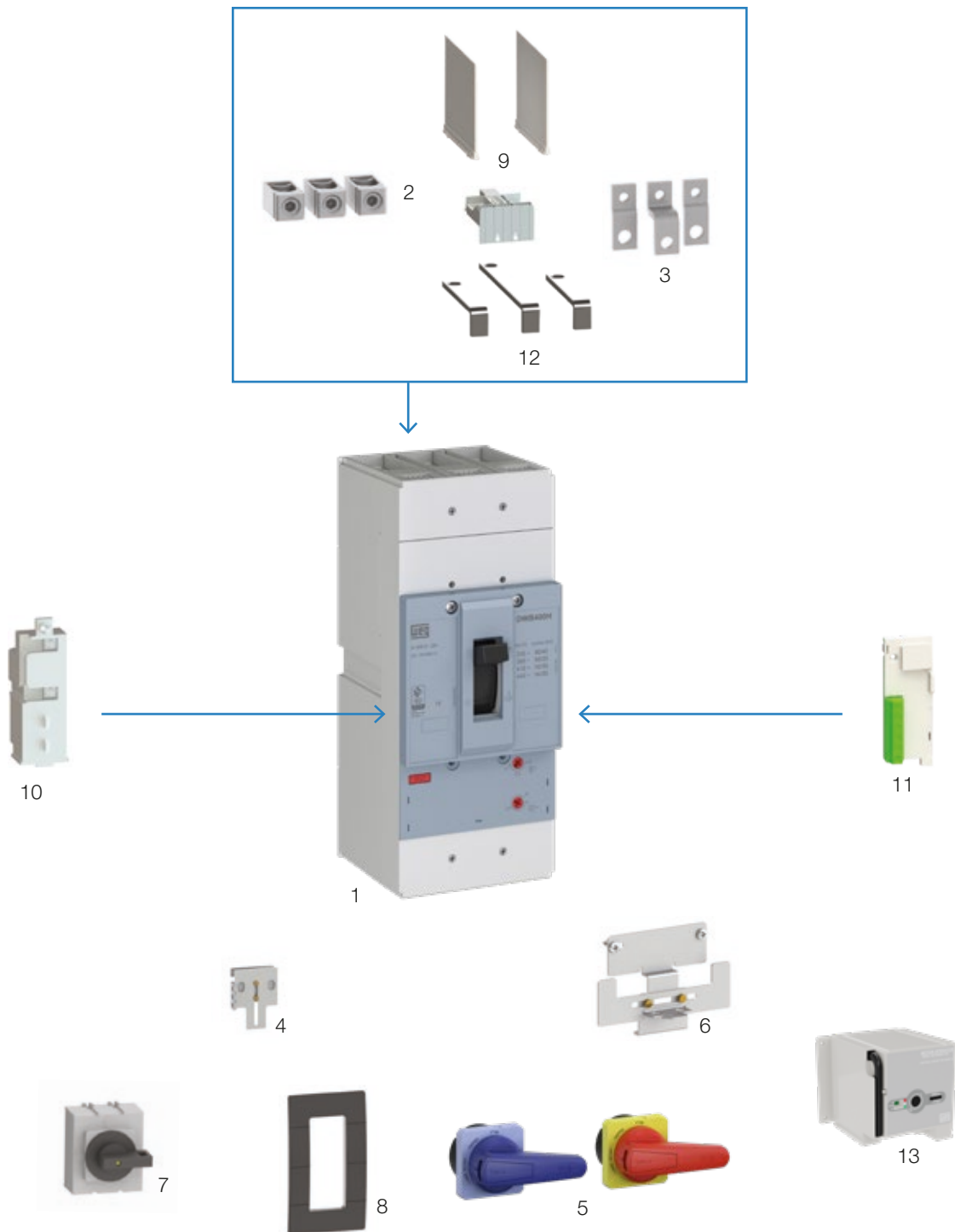

- | | |
|---|--|
| 1 - DWB400 circuit breaker | 7 - MRI - internal rotary operating handle |
| 2 - PC - terminal lugs | 8 - MP - escutcheon |
| 3 - BE - straight extension bar | 9 - PB - phase barrier |
| 4 - PL - padlocking device | 10 - BS or BD - undervoltage release or shunt release |
| 5 - MRXL - panel door rotary operating handle (length of handle 105 mm) | 11 - BC - auxiliary contact block |
| 6 - BLIM - mechanical interlock | 12 - CT - 90° connection extension bars (CP 90° connection extension bars protection cover included) |
| | 13 - AM - Motor operator |

Accessories

Overview - DWB800

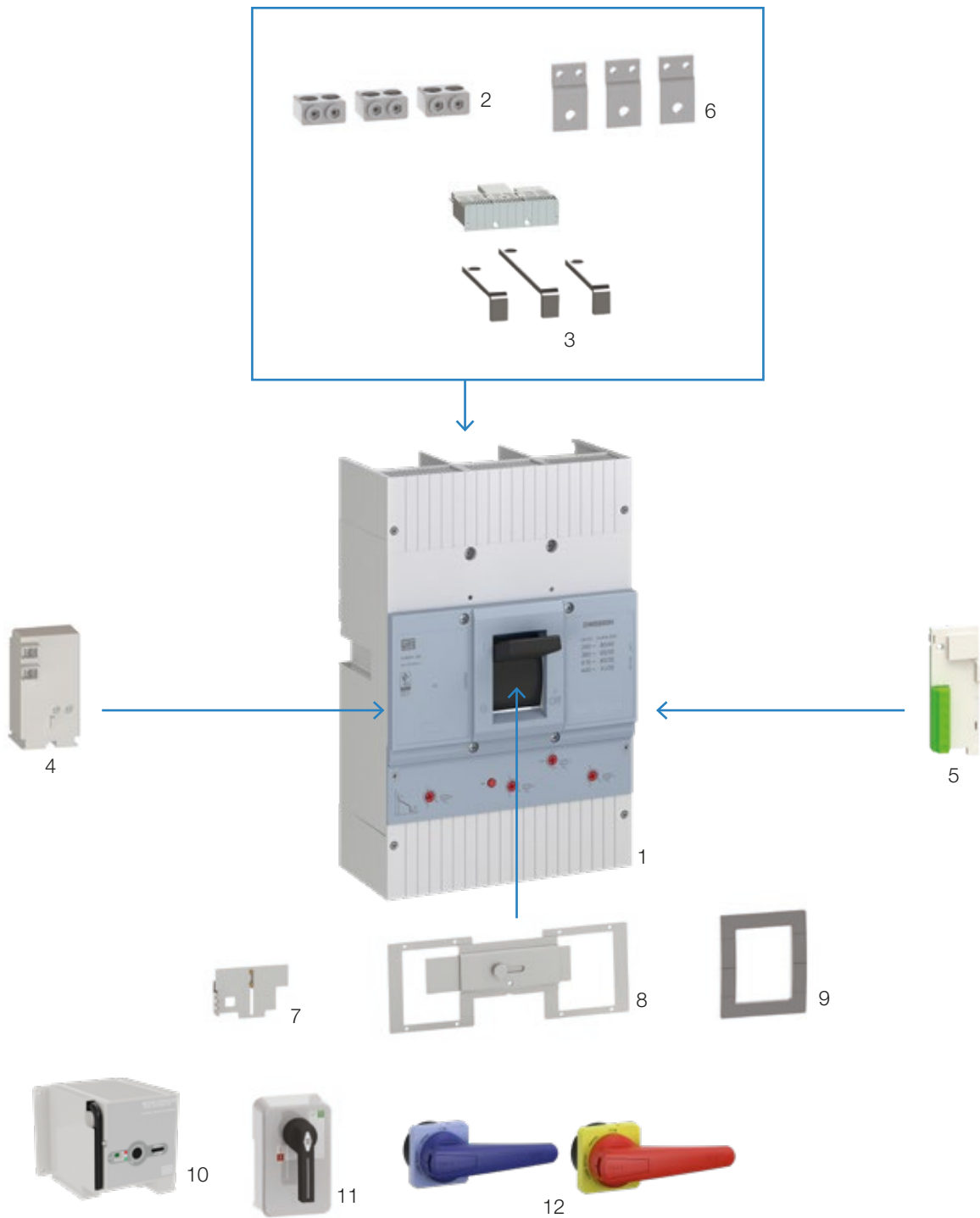

- 1 - DWB800 circuit breaker
- 2 - PC - terminal lugs
- 3 - CT - 90° connection extension bars (CP 90° connection extension bars protection cover included)
- 4 - BS or BD - undervoltage release or shunt release
- 5 - BC/AL - alarm/contact block
- 6 - BE - straight extension bar

- 7 - PL - padlocking device
- 8 - BLIM - mechanical interlock
- 9 - MP - escutcheon
- 10 - AM - motor operator
- 11 - MRI - internal rotary operating handle
- 12 - MRXL - panel door rotary operating handle (length of handle 158 mm)

Accessories

Overview - DWB1000

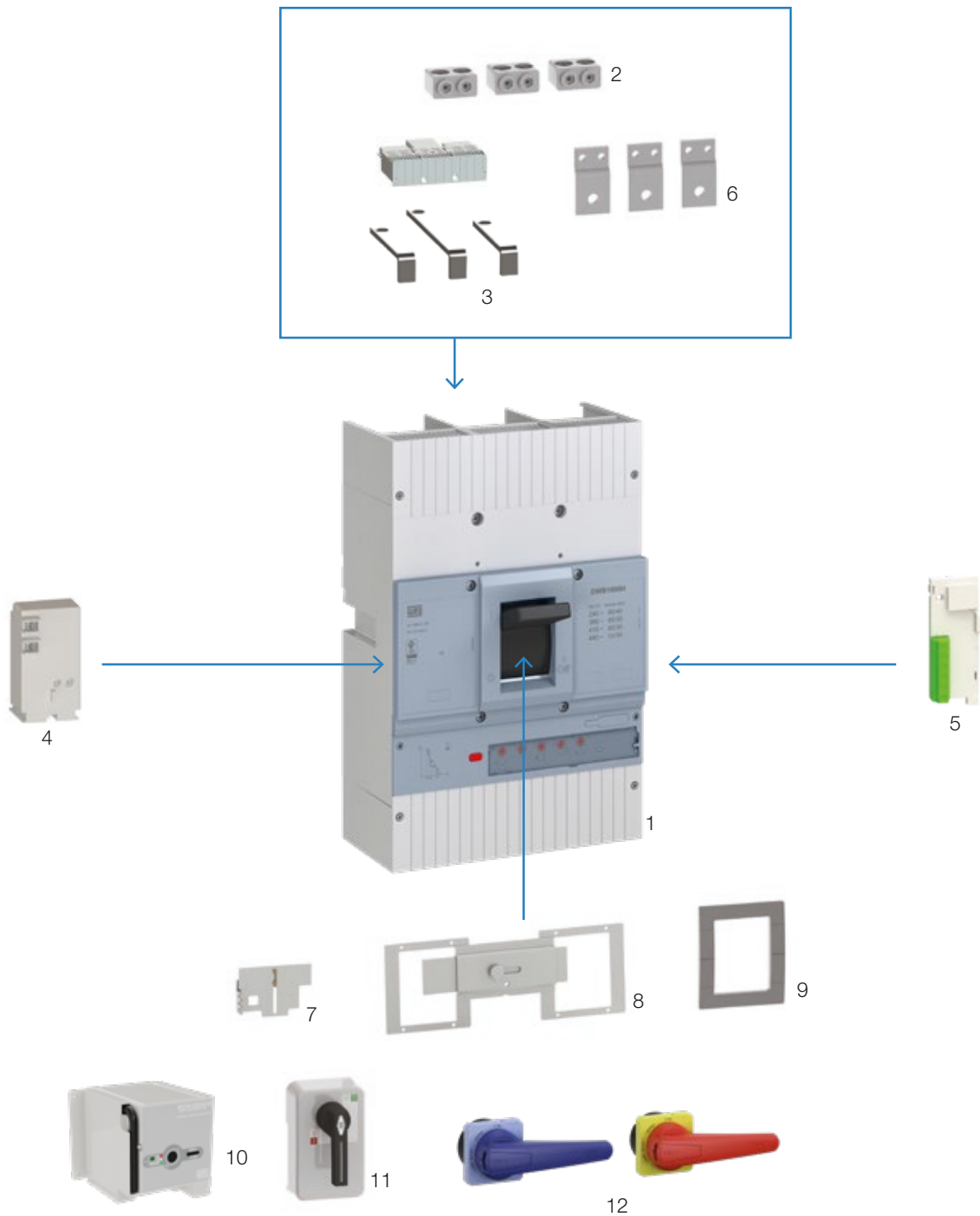

- | | |
|---|--|
| 1 - DWB1000 circuit breaker | 7 - PL - padlocking device |
| 2 - PC - terminal lugs | 8 - BLIM - mechanical interlock |
| 3 - CT - 90° connection extension bars (CP 90° connection extension bars protection cover included) | 9 - MP - escutcheon |
| 4 - BS or BD - undervoltage release or shunt release | 10 - AM - motor operator |
| 5 - BC/AL - alarm/contact block | 11 - MRI - internal rotary operating handle |
| 6 - BE - straight extension bar | 12 - MRXL - panel door rotary operating handle (length of handle 158 mm) |

Accessories

Overview - DWB1600

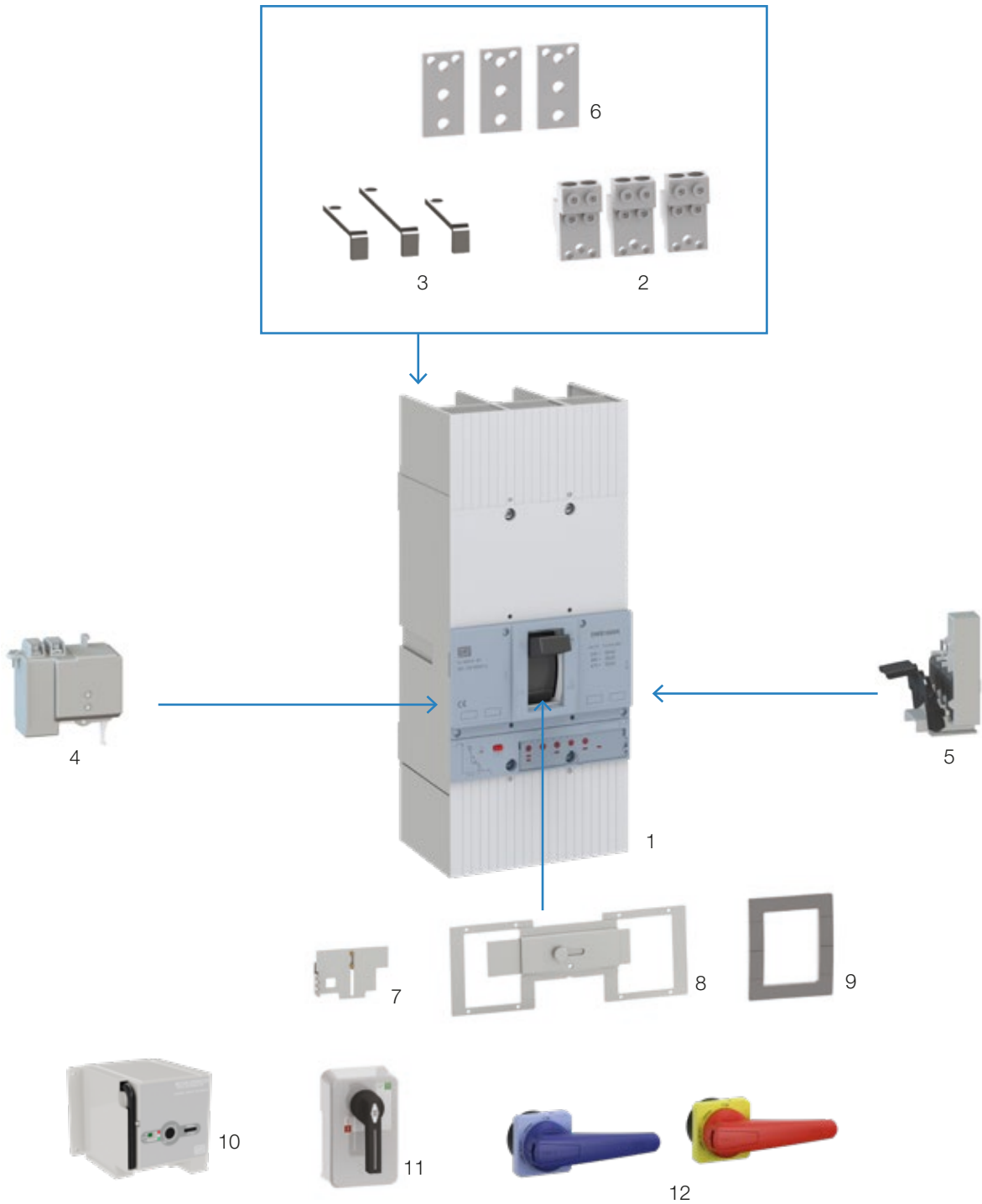

- 1 - DWB1600 circuit breaker
- 2 - PC - terminal lugs
- 3 - CT - 90° connection extension bars
- 4 - BS or BD - undervoltage release or shunt release
- 5 - BC/AL - alarm/contact block
- 6 - BE - straight extension bar
- 7 - PL - padlocking device
- 8 - BLIM - mechanical interlock
- 9 - MP - escutcheon
- 10 - AM - motor operator
- 11 - MRI - internal rotary operating handle
- 12 - MRXL - panel door rotary operating handle (length of handle 158 mm)

Note: the DWB1600 circuit breaker does not have the CP 90° connection extension bars protection cover.

Accessories

Overview

Description	Reference	DWB160	DWB250	DWB400	DWB800	DWB1000	DWB1600
Auxiliary/alarm contact ¹⁾²⁾	BC1-NOC	√	√	√	√	√	√
	BC2-NOC	√	√	√	√	√	√
	BC3-NOC	-	-	-	-	-	√
	AL1-NOC	√	√	√	√	√	√
	BC/AL2-NOC	√	√	√	√	√	√
	BC/AL3-NOC	-	-	-	-	-	√
Undervoltage release BS ²⁾	110/127 V ac	-	-	√	√	√	√
	220/240 V ac	-	-	√	√	√	√
	380-415 V ac	-	-	√	√	√	√
	440-480 V ac	-	-	√	√	√	√
	24 V dc	-	-	√	√	√	√
	48 V dc	-	-	√	√	√	√
	24 V ac / V dc	√	√	-	-	-	-
	48 V ac / V dc	√	√	-	-	-	-
	60 V ac / V dc	√	√	-	-	-	-
	110/130 V ac / V dc	√	√	-	-	-	-
220/250 V ac / V dc	√	√	-	-	-	-	
Shunt trip BD ²⁾	24 V ac / V dc	√	√	√	√	√	√
	48 V ac / V dc	√	√	√	√	√	√
	60 V ac / V dc	√	√	-	-	-	-
	110/130 V ac / V dc	√	√	√	√	√	√
	220/250 V ac / V dc	√	√	√	√	√	√
Panel door rotary operating handle	MR / MRX	√	√	√	√	√	√
	MRXS	√	√	-	-	-	-
	MRXL	√	√	√	√	√	√
Internal rotary handle	MRI	-	-	√	√	√	√
Din rail base	BFR	√	√	-	-	-	-
Front mechanical interlock	BLIM	√	√	√	√	√	√
Padlocking device	PL	√	√	√	√	√	√
90° connection extension bars	CT	√ ⁵⁾	√ ⁵⁾	√	√	√	√
Straight extension bars	BE	√	√	√	√	√	√
Terminal lugs	PC	√ ³⁾	√	√	√	√	√
Escutcheon	MP	√	√	√	√	√	√
Motor operator	AM	-	-	√	√	√	√
Phase barrier	PB	√	√	√	-	-	-
90° connection extension bars protection cover	CP	√	√	√	√	√	-

Notes: 1) For combination of BC + AL, always consider the BC/AL block. It is not possible to assemble individual blocks on the circuit breaker.
For example: BC1 + AL1. Replace this combination by the BC/AL2 block.

2) DWB circuit breakers are supplied without accessories. The accessories must be purchased separately and assembled at the customer's.

3) Included in the product.

4) All accessories indicated can also be used on IWB switch disconnectors.

5) Only for DWB160B and N and DWB250B and N circuit breakers. Not applicable for circuit-breakers DWB160L and DWB250L.

Internal accessories

Maximum combinations of internal accessories

Model	DWB160 ¹⁾						DWB250 ¹⁾						DWB400 ¹⁾						DWB800 / DWB1000 ¹⁾						DWB1600 ¹⁾															
	2P / 3P			4P			2P / 3P			4P			2P / 3P			4P			2P / 3P			4P			3P			4P												
Auxiliary contacts BC ²⁾	2	1	2	1	2	1	2	1	2	1	2	1	4	3	4	3	2	1	2	1	4	3	4	3	4	3	4	3	8	7	8	7	3	2	3	2	6	4	6	4
Alarm contact AL ²⁾	0	1	0	1	0	1	0	1	0	1	0	1	0	1	0	1	0	1	0	1	0	1	0	1	0	1	0	1	0	1	0	1	0	1	0	1	0	1	0	1
Shunt trip BD	1	1	0	0	1	1	0	0	1	1	0	0	1	1	0	0	1	1	0	0	1	1	0	0	1	1	0	0	1	1	0	0	1	1	0	0	1	1	0	0
Undervoltage release BS	0	0	1	1	0	0	1	1	0	0	1	1	0	0	1	1	0	0	1	1	0	0	1	1	0	0	1	1	0	0	1	1	0	0	1	1	0	0	1	1

Notes: 1) Sold separately only. It is not sold assembled on the circuit breaker.

2) For combination of BC + AL, always consider the BC/AL block. It is not possible to assemble individual blocks on the circuit breaker. BC1 + AL1, replace this combination by the BC/AL2 block.

Assembly position of the internal accessories



Auxiliary and alarm contact blocks

BC - auxiliary contact: signals the open and closed position of the main contacts. Reversing type (1 NOC).

AL - alarm contact: signals the thermal or magnetic release of the circuit breaker. Reversing type (1 NOC).

BC/AL - auxiliary + alarm contact set: performs the 2 functions above in different contacts in a single set.



Configuration of the contact/ alarm block ¹⁾⁴⁾	DWB160 Ref. WEG ³⁾	DWB250 Ref. WEG ³⁾	DWB400 Ref. WEG ³⁾	DWB800 Ref. WEG ³⁾	DWB1000 Ref. WEG ³⁾	DWB1600 Ref. WEG ³⁾	Quantity of contacts	
							Auxiliary	Alarm
BC1			10848664			10046832	1 NOC	-
BC2			11026395			10046833	2 NOC	-
BC3			-			10046834	3 NOC	-
AL1			11026397			10186511	-	1 NOC
BC/AL2			11026396			11648561	1 NOC	1 NOC
BC/AL3			-			11648787	2 NOC	1 NOC

Conduction capacity of the contact blocks				
Voltage	Load type	DWB160 / DWB250 / DWB400 / DWB800 / DWB1000		DWB1600
		250 V ac	Resistive	
	Inductive ²⁾	3 A		12 A
125 V ac	Resistive	6 A		15 A
	Inductive ²⁾	3 A		12 A
250 V dc	Resistive	0.3 A		0.3 A
	Inductive ²⁾	0.2 A		0.3 A
125 V dc	Resistive	0.4 A		0.6 A
	Inductive ²⁾	0.2 A		0.6 A

Notes: 1) For combinations of BC and AL (2 or 3 BCs and BC + AL) always consider the assembled set (BC2, BC3, BC/AL2 or BC/AL3). It is not possible to assemble individual blocks of BC and AL on the circuit breaker.

2) It must not be used to drive motors.

3) Sold separately only. It is not sold assembled on the circuit breaker.

4) For cable connection, consider maximum cross section of 1.5 mm² and torque of 0.8 Nm.

Internal accessories

Auxiliary and alarm contact blocks

Wiring diagrams of the DWB circuit breaker

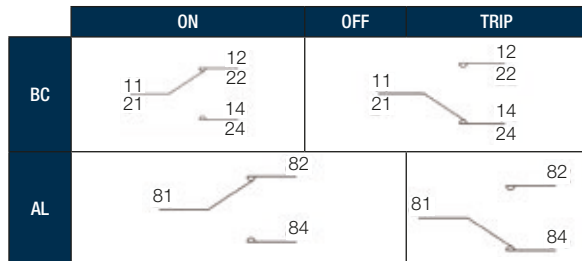

Wiring diagrams of the DWB1600 circuit breaker

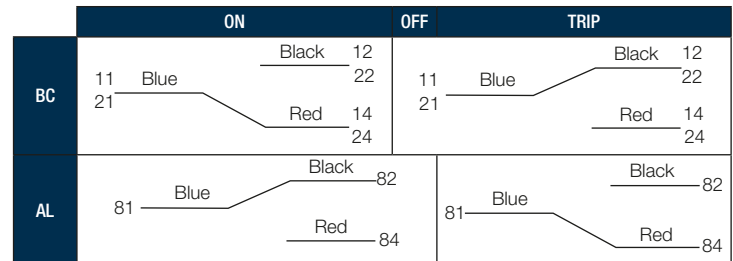

Undervoltage release and shunt trip

BS - undervoltage release: it trips the circuit breaker when its operating voltage is below 35% of its rated value. That is, when the undervoltage release power supply is $U_o \leq 0.35 \times U_n$, the opening of the circuit breaker is ensured. When the voltage is within the range $0.35 < U_o < 0.7$, trip may occur, and above $0.7 \times U_n$ trip will not occur.

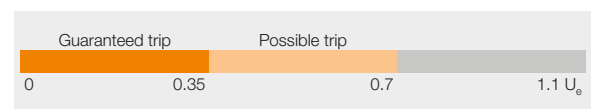

BD - shunt trip: when the shunt trip is energized by a voltage pulse, the circuit breaker trips. The trip is endured when the shunt trip command voltage is $U_o > 0.70$. That is, when its operating range is $0.70 < U_o < 1.10$ of the rated voltage, the circuit breaker will trip.



Note: to close the circuit breaker, BS must be energized.

BS - undervoltage release and BD - shunt trip

	Rated Voltage (U_n)	Voltage code	DWB160	Consumption	DWB400	Consumption	DWB800	Consumption	DWB1600	Consumption
			DWB250 Ref. WEG ²⁾		Ref. WEG ²⁾		Ref. WEG ²⁾		Ref. WEG ²⁾	
Undervoltage release BS	110-127 V ac	D60	-	-	12687427	2,5 VA	13421493	5 VA	10046787	5 VA
	220-240 V ac	D66	-	-	12687479	5 VA	13421489	5 VA	10046727	5 VA
	380-415 V ac	D70	-	-	12687480	8 VA	13421495	5 VA	10046726	5 VA
	440-480 V ac	D74	-	-	12687481	9 VA	13421496	5 VA	10046762	5 VA
	24 V dc	C03	-	-	12687425	1 W	13421490	5 W	10046785	5 W
	48 V dc	C07	-	-	12687426	1 W	13421491	5 W	10046786	5 W
	24 V ac / V dc	E26	11338330	2,5 VA	-	-	-	-	-	-
Shunt trip BD ¹⁾	48 V ac / V dc	E27	11338318	2,0 VA	-	-	-	-	-	-
	60 V ac / V dc	E28	11442836	2,5 VA	-	-	-	-	-	-
	110-130 V ac / V dc	E10	11338324	1,5 VA	-	-	-	-	-	-
	220-250 V ac / V dc	E15	10853866	2,5 VA	-	-	-	-	-	-
	24 V ac / V dc	E26	11338271	0,5 VA	12687485	130 VA	13421393	90 VA	10046782	90 VA
	48 V ac / V dc	E27	11338248	0,5 VA	12687486	50 VA	13421394	90 VA	10046783	90 VA
60 V ac / V dc	E28	11442871	0,5 VA	-	-	-	-	-	-	
110-130 V ac / V dc	E10	11338254	0,5 VA	12687482	65 VA	13421391	90 VA	10046725	90 VA	
220-250 V ac / V dc	E15	10850989	0,5 VA	12687483	65 VA	13421392	90 VA	10046724	90 VA	
Min./max cable			0.5-1.5 mm ² 20-16 AWG		0.5-1.5 mm ² 20-16 AWG		0.5-1.5 mm ² 20-16 AWG		0.5-1.5 mm ² 20-16 AWG	
Length to strip the wire min./max.			4-6 mm		5-7 mm		5-7 mm		5-7 mm	
Tightening torque of the terminal (N.m)			0.8		0.8		0.8		0.8	
Fixing tightening torque (N.m)			0.3		0.8		Snap fit		0.8	



Notes: 1) It has a device to keep the coil de-energized after the trip pulse.
2) Sold separately only. It is not sold assembled on the circuit breaker.

Wiring diagrams



External accessories

Panel door operating handles

Handle (IP66)

- When in ON position, panel door cannot be opened, unless a tool is used to bypass the panel door locking system, allowing thermometry of the panel.
- Circuit breaker and panel door padlocking in OFF position using 1 to 3 padlocks.

Coding

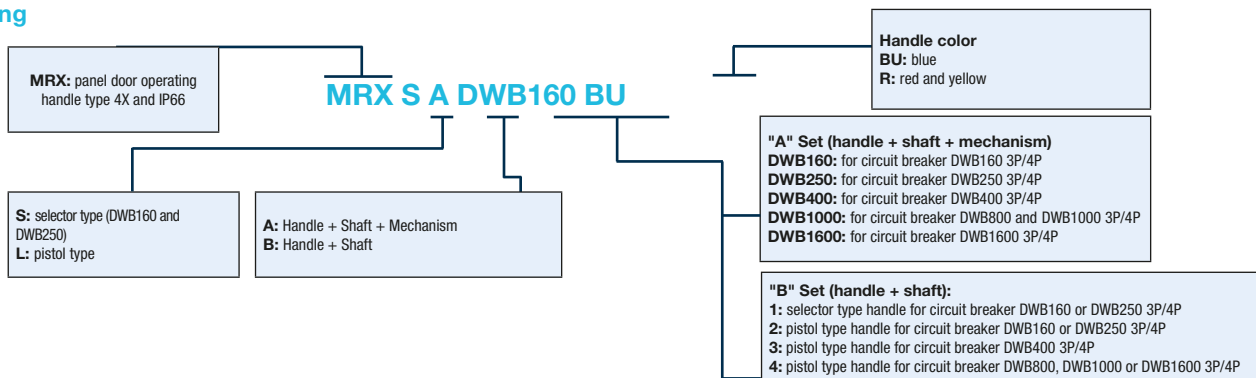

Panel door operating handles (IP66)

"A" set: handle + shaft + mechanism

Ref. WEG	Description	Circuit breaker	Shaft (mm)	Length of handle (mm)	Handle color
13624516	MRXS-A-DWB160-R	DWB160 2P/3P/4P	460	-	Red and yellow
13624549	MRXS-A-DWB250-R	DWB250 2P/3P/4P	460	-	Red and yellow
13624551	MRXL-A-DWB160-R	DWB160 2P/3P/4P	460	105	Red and yellow
13624610	MRXL-A-DWB250-R	DWB250 2P/3P/4P	460	105	Red and yellow
13624612	MRXL-A-DWB400-R	DWB400 2P/3P/4P	460	105	Red and yellow
13624616	MRXL-A-DWB1000-R	DWB800 / DWB1000 3P/4P	460	158	Red and yellow
13624628	MRXL-A-DWB1600-R	DWB1600 2P/3P/4P	460	158	Red and yellow
13624517	MRXS-A-DWB160-BU	DWB160 2P/3P/4P	460	-	Blue
13624550	MRXS-A-DWB250-BU	DWB250 2P/3P/4P	460	-	Blue
13624553	MRXL-A-DWB160-BU	DWB160 2P/3P/4P	460	105	Blue
13624611	MRXL-A-DWB250-BU	DWB250 2P/3P/4P	460	105	Blue
13624613	MRXL-A-DWB400-BU	DWB400 2P/3P/4P	460	105	Blue
13624617	MRXL-A-DWB1000-BU	DWB800 / DWB1000 3P/4P	460	158	Blue
13624629	MRXL-A-DWB1600-BU	DWB1600 3P/4P	460	158	Blue

Notes: 1) Padlocks 4 up to 8 mm may be fit to the handles.
2) Sold separately only. It is not sold assembled on the circuit breaker.

"B" set: handle + shaft

Ref. WEG	Description	Circuit breaker	Shaft (mm)	Length of handle (mm)	Handle color
13624630	MRXS-B-1-R	DWB160 / DWB250 2P/3P/4P	460	-	Red and yellow
13624633	MRXL-B-2-R	DWB160 / DWB250 2P/3P/4P	460	105	Red and yellow
13624635	MRXL-B-3-R	DWB400 2P/3P/4P	460	105	Red and yellow
13624660	MRXL-B-4-R	DWB800 / DWB1000 / DWB1600 3P/4P	460	158	Red and yellow
13624632	MRXS-B-1-BU	DWB160 / DWB250 2P/3P/4P	460	-	Blue
13624634	MRXL-B-2-BU	DWB160 / DWB250 2P/3P/4P	460	105	Blue
13624636	MRXL-B-3-BU	DWB400 2P/3P/4P	460	105	Blue
13624661	MRXL-B-4-BU	DWB800 / DWB1000 / DWB1600 3P/4P	460	158	Blue

Notes: 1) Padlocks 4 up to 8 mm may be fit to the handles.
2) Sold separately only. It is not sold assembled on the circuit breaker.

Only mechanism

Ref. WEG	Description	Circuit breaker
13624244	MRH DWB160	DWB160 2P/3P/4P
13624246	MRH DWB250	DWB250 2P/3P/4P
13624247	MRH DWB400	DWB400 2P/3P/4P
13624278	MRH DWB1000E	DWB800 / DWB1000 3P/4P
13624279	MRH DWB1600E	DWB1600 3P/4P

Note: 1) Sold separately only. It is not sold assembled on the circuit breaker.

External accessories



Shaft support

- Recommended when the shaft length is more than indicated in next table.



MRI - rotary operating handle for direct operation of the circuit breaker

- It allows rotary operation of the circuit breaker
- Padlocking in the OFF position with up to three padlocks



Mounting

BFR - DIN rail base

- It allows fast assembly of the circuit breaker on DIN rail 35 mm



Lock

BLIM - front mechanical interlock

- Mechanical lock between two circuit breakers, preventing simultaneous closing (ON)
- It allows the use of 1 to 3 padlocks of 4...8 mm

Ref. WEG	Description	Circuit breaker	Shaft length to use of support
13878675	MR DWB400	DWB400	> 380 mm
13878676	MR DWB800-1600	DWB800/DWB1000/DWB1600	> 320 mm

Note: sold separately only. It is not sold assembled on the circuit breaker. Accessory may be used on frames 3P and 4P.

	Circuit	Ref. WEG
MRI DWB400	DWB400	12729396
MRI DWB800-1000	DWB800 DWB1000	13471816
MRI DWB1600	DWB1600	10046795

Note: MRI accessory may be used on frames 3P and 4P.

	Circuit	Ref. WEG
BFR DWB160	DWB160	12730039
BFR DW B250	DWB250	12139063

Note: BFR accessory may be used on frames 3P and 4P.

	Circuit	Ref. WEG
BLIM DWB160 3P	DWB160	11639815
BLIM DWB160 4P	DWB160	12729994
BLIM DWB250 3P	DWB250	11639817
BLIM DWB250 4P	DWB250	12729995
BLIM DWB400 3P	DWB400	12729996
BLIM DWB400 4P	DWB400	12729997
BLIM DWB800-1600 3P	DWB800 / DWB1000 / DWB1600	13471814
BLIM DWB800-1600 4P	DWB800 / DWB1000 / DWB1600	13471815

External accessories



Lock

PLW - padlocking device

- It allows padlocking the circuit breaker in the OFF position.
- It allows the use of 1 to 3 padlocks of 4...8 mm

	Circuit	Ref. WEG
PL DWB160 3P	DWB160 2P/3P	11217445
PL DWB160 4P	DWB160 4P	12729993
PL DWB250	DWB250 2P/3P/4P	11640142
PL DWB400	DWB400 2P/3P/4P	11217482
PL DWB800-1600	DWB800 / DWB1000 / DWB1600 (three poles and four poles)	13471813



Connection

CT - 90° connection extension bars

- It allows direct connection of bars or cables from the back side of the circuit breaker

	Circuit	Cable / bar	Ref. WEG
CT DWB160 3P ¹⁾	DWB160 B/N	Use the same cable cross section and dimensions as those of bars recommended in the technical characteristics	12730075
CT DWB250 3P ¹⁾	DWB250 B/N		12288234
CT DWB400 3P ¹⁾	DWB400		12730076
CT DWB800-1000 3P ¹⁾	DWB800 / DWB1000		13471874
CT DWB1600 3P	DWB1600		10046808

Note: 1) CP 90° connection extension bars protection cover included.



CP - 90° connection extension bars protection cover

- Accessory only used with 90° connection extension bars to protect terminals and bars
- It protects the operators and everyone involved in the process against inadvertent contact

	Circuit	Ref. WEG
CP protection cover DWB160 3P	DWB160 B/N	13544950
CP protection cover DWB250 3P	DWB250 B/N	13544949
CP protection cover DWB400 3P	DWB400	12731654
CP protection cover DWB800-1000 3P	DWB800 / DWB1000	13544948

Note: the codes of this table refer to the supply of the CP 90° connection extension bars protection cover only. 1 unit refers to the covering of the 3 phases. No protection cover for 4 poles is available. Accessory available for DWB circuit breakers only. The DWB1600 circuit breaker, for example, does not have the 90° connection extension bars protection cover.



BE - straight extension bars

- It extends the terminal length and allows connecting busbars and mounting cables with terminals
- 3-piece set

	Circuit	Cable / bar	Ref. WEG
BE DWB160 3P	DWB160	Use the same cable cross section and dimensions as those of bars recommended in the technical characteristics (installation topic)	11279346
BE DWB160 4P	DWB160		11780009
BE DWB250 3P	DWB250		11279347
BE DWB250 4P	DWB250		12714046
BE DWB400 3P	DWB400		12730070
BE DWB400 4P	DWB400		11780016
BE DWB800-1000 3P	DWB800 / DWB1000		13471872
BE DWB800-1000 4P	DWB800 / DWB1000		13471873
BE DWB1600 3P	DWB1600		10046553
BE DWB1600 4P	DWB1600		11780050

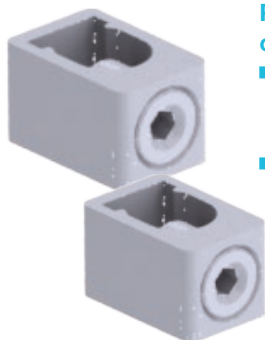

PC - cable connection terminal

- It allows direct connection of cables to the circuit breaker
- 3-piece set

	DWB160 ³⁾	DWB250	DWB400	DWB800 / DWB1000	DWB1600
Round terminal lugs schematic drawing					
Description		PC DWB250 3P	PC DWB400 3P	PC DWB800-1000 3P	PC DWB1600 3P
Number of cables	Round terminal lugs for one cable	Round terminal lugs for one cable (accessory)	Round terminal lugs for one cable (accessory)	Round terminal lugs for two cables (accessory)	Round terminal lugs for four cables (accessory)
Maximum cable cross section (mm ²)	70	120	240	240	240
Minimum cable cross section (mm ²)	4	25	35	95	185
Tightening torque (mm)	6	25	30	55	55
Cable length to be stripped to use terminal lugs (mm)	16	25	25	28	38
Reference WEG	Supplied with the circuit breaker	11277469	12730045	13471871	10046555

External accessories

Finishing⁴⁾

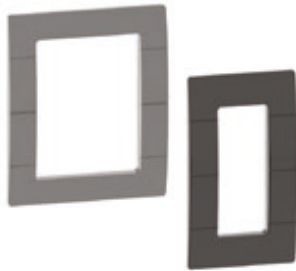

MP - escutcheon for circuit breaker operation on panel door

- It provides perfect finishing between the circuit breaker and panel door

	Circuit	Ref. WEG
MP DWB160	DWB160	11338525
MP DWB250	DWB250	11338526
MP DWB400	DWB400	12730041
MP DWB800-1600	DWB800 DWB1000 DWB1600	13471876
MP DWB1600	DWB1600	10186520

Notes: 1) The accessories are not sold assembled on the DWB circuit breakers. Sold separately only.
 2) Recommended cross sections for cables with stranding class 2, insulation of PVC -70 °C.
 3) On DWB160 circuit breakers, the cable connection terminal is included in the factory supply. Not sold as accessory.
 4) MP accessory can be used on frames 3P and 4P.

PB - phase barrier

- The circuit breakers are supplied with two phase barriers. Those barriers must be installed on the line input side. For voltages above 500 Volts, phase barriers must also be installed on the circuit breaker outputs. For such application, the phase barriers must be purchased. They are not supplied with the circuit breaker.

See table with directions for use of the phase separator in the section "Use of Phase Barrier and Terminal Cover".

	Circuit breaker	Ref. WEG
PB DWB160-250	DWB160 / DWB250	12403111
PB DWB400	DWB400	12731651

External accessories

Motor operator

- The motor operator is a mechanical and electrical device whose main characteristics are:
- Remote or local operation of the circuit breaker
- Control voltage (motor power supply):
 - 24 V dc
 - 125 V dc
 - 110 V ac; 50/60 Hz; 110 V dc
 - 230 V ac 50/60 Hz; 220 V dc
- Use on DWB400, DWB800, DWB1000 and DWB1600 circuit breakers

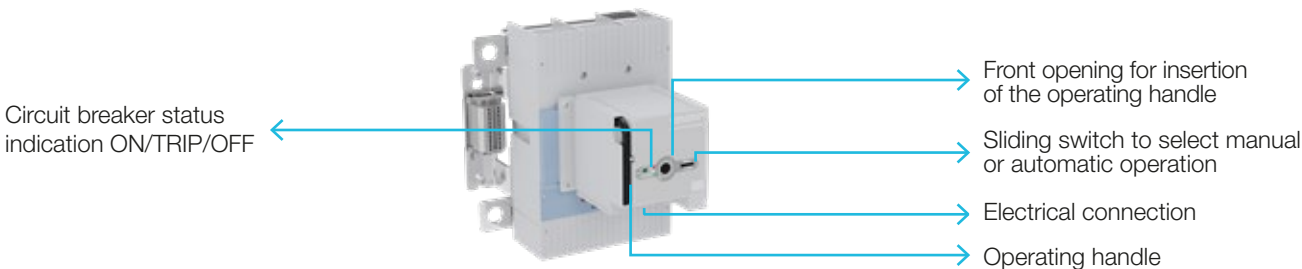

For MANUAL operation, it is necessary:

- 1 - Set the sliding switch to MANUAL;
- 2 - Insert the operating handle (located on the side bracket) into the front slot and rotate it 180° clockwise.
Rotate only 180° to ensure the operation of the internal micro switch;
- 3 - Put the handle back on the side bracket.

For AUTOMATIC operation, it is necessary:

- 1 - Set the sliding switch to AUTO. In this position it is possible to operate the circuit breaker remotely by sending ON/OFF signals;
- 2 - Please, do not send ON/OFF signals at the same time during automatic operation;
- 3 - For circuit breakers equipped with undervoltage release, energize the release before operating the motor operator.

If the circuit breaker trips (overload or short-circuit tripping), for manual or automatic operation it is necessary to turn it "OFF" before turning it "ON".

Wiring diagrams

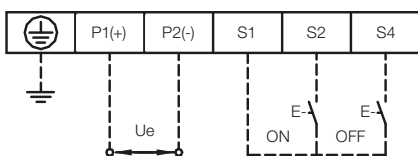

Cable connections	
Minimum/maximum cable	1.5 to 2.5 mm ²
Tightening torque (N.m)	1.2 Nm

Technical data of the motor operator¹⁾

Reference	Applicable circuit breaker	Power supply	Response time (ms)		Consumption (W)	Operations per hour	Code
			Opening	Closing			
AM DWB400 E29	DWB400	110 V ac - 50 and 60 Hz / 110 V dc	700	420	35	20	15505489
AM DWB400 E46		230 V ac - 50 and 60 Hz / 220 V dc	700	420	35	20	15506644
AM DWB400 C03		24 V dc	700	420	35	20	15506646
AM DWB400 C13		125 V dc	700	420	35	20	15505490
AM DWB800-1600 E29	DWB800 / DWB1000 / DWA1600	110 V ac - 50 and 60 Hz / 110 V dc	700	420	35	20	14861645
AM DWB800-1600 E46		230 V ac - 50 and 60 Hz / 220 V dc	700	420	35	20	14861647
AM DW800-1600 C03		24 V dc	700	420	35	20	14861644
AM DW800-1600 C13		125 V dc	700	420	35	20	14937250

Note: 1) The motor operator is sold separately from the circuit breaker.

External accessories

CTM - mechanical changeover

The CTM is a set of 2 DW circuit breakers or switches, with or without motorization and internal accessories installed on a BTIM base with mechanical interlock between them. The mechanical interlock prevents turning on the two coupled circuit breakers or switches simultaneously.

CTM advantages

- Quick installation: supplied assembled, with terminal strips for electrical connections
- Safety: all sets are factory tested after the assembly
- Space saving: compact set and easy to install

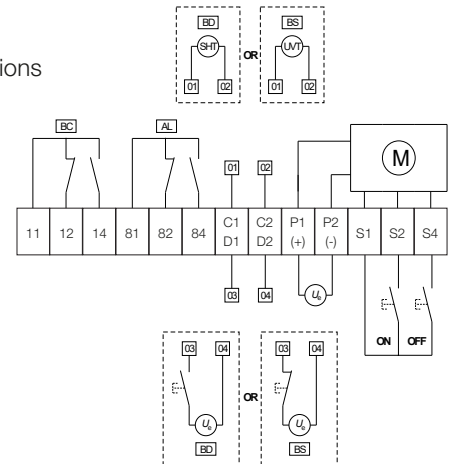

Mechanical interlocking back base (BTIM)¹⁾

Reference	Applicable circuit breaker	Code
BTIM400 3P	DWB400 - 3 poles	13473234
BTIM400 4P	DWB400 - 4 poles	13473233
BTIM1000 3P	DWB800 / DWB1000 - 3 poles	13404161
BTIM1000 4P	DWB800 / DWB1000 - 4 poles	13404164
BTIM1600 3P	DWB1600 - 3 poles	13404163
BTIM1600 4P	DWB1600 - 4 poles	13404162

Note: 1) BTIM is not sold individually; only in CTM, according to the coding below.

Coding



E.g.: **CTM 1600-S 1600 E S 1250 E 3P-10 E26 0 C03**

CTM Coding Accessory coding

CTM	Coding of the circuit breakers								Coding of the circuit breaker accessories						
	1600	-	S	1600	E	S	1250	E	3P	-	1	0	E26	0	C03
BTIM base definition ¹⁾	Circuit breaker frame	Circuit breaker definition ¹⁾			Circuit breaker definition ²⁾			Number of poles - 3 or 4 poles ⁴⁾	Contacts ⁵⁾		Shunt trip - setting of the coil voltage ⁶⁾	Undervoltage release - setting of the coil voltage ⁶⁾	Motor operator-MO voltage ⁷⁾		
	400 = DWB400	Breaking capacity	Circuit breaker rated current ²⁾	Protection type ³⁾	Breaking capacity	Circuit breaker rated current ²⁾	Protection type ³⁾		Auxiliary contact	Alarm contact					
	1,000 = DWB800														
	1,000 = DWB1000														
1,600 = DWB1600															

- Notes: 1) It is not possible to use circuit breakers with different frames and number of poles on the BTIM.
 2) Circuit breakers may have different rated currents, as long as they have the same frame.
 3) Circuit breakers may have different protection types.
 4) Definition of the number of poles for the BTIM and circuit breakers. It is not possible to have different poles between the circuit breakers and BTIM.
 5) Regardless of the circuit-breaker model, the maximum number of contacts in the CTM must be dimensioned considering 3P circuit-breakers and according to the quantities indicated in the "Maximum combinations of Internal Accessories" table. IMPORTANT: It is not possible to set different quantities of contacts between the circuit-breakers in the CTM.
 6) When defining a shunt trip or undervoltage release, they are considered one for each circuit breaker. It is not possible to have both simultaneously on the same circuit breaker.
 7) When defining the motor operator, one MO is considered for each circuit breaker. It is not possible to have one circuit breaker with MO and one without.

Installation

Installation of the circuit breakers

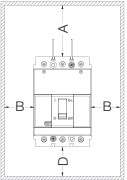
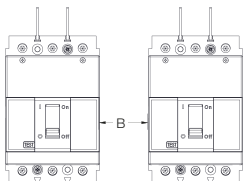
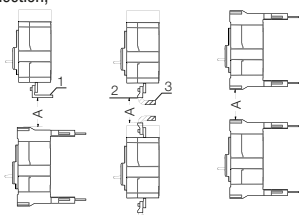
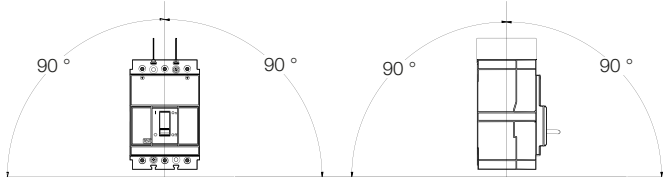
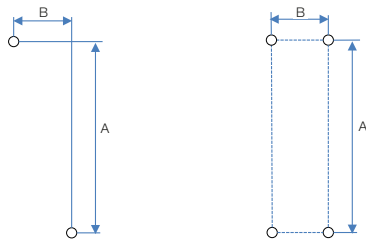
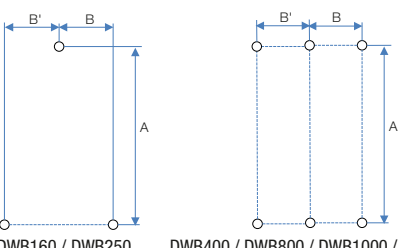
IEC 60947-2 standard	Un.	DWB160	DWB250	DWB400	DWB800	DWB1000	DWB1600
Recommended mounting distances (mm) 	mm	A: 50 C: 20 D: 20	A: 50 C: 20 D: 20	A: 70 C: 30 D: 30	A: 100 C: 30 D: 30	A: 100 C: 30 D: 30	A: 100 C: 30 D: 30
Recommended distances between circuit breakers for side by side mounting 	mm	B:10	B:10	0	0	0	0
Recommended distances between circuit breakers for vertical mount 1) Non-insulated connection; 2) Insulated cable; 3) Terminal lugs. 	mm	90	150	180	200	200	200
Assembly positions 	-						
Dimensional drawing and mounting 2P and 3P  DWB160 / DWB250 DWB400 / DWB800 / DWB1000 / DWB1600	mm	A: 100/121 (limiter) B: 25	A: 124/149 (limiter) B: 35	A: 199 B: 35	A: 230 B: 70	A: 230 B: 70	A: 265 B: 70
Dimensional drawing and mounting 4P  DWB160 / DWB250 DWB400 / DWB800 / DWB1000 / DWB1600	mm	A: 100/121 (limiter) B=B': 25	A: 121/149 (limiter) B=B': 35	A: 199 B=B': 35	A: 230 B=B': 70	A: 230 B=B': 70	A: 265 B: 70 B'=74
Fixing screw to plate 2P 3P	-	B/N: M4 x 76 x 2 parts L: M4x76 x 1 part + M4x144 x 1 part	B/N: M4 x 76 x 2 parts L: M4x76 x 1 part + M4x144 x 1 part	M5 x 100 x 4 parts	M5 x 60 x 4 parts	M5 x 60 x 4 parts	M8 x 140 x 4 parts
Fixing screw to plate 4P	-	B/N: M4 x 76 x 3 parts	B/N: M4 x 76 x 3 parts	M5 x 100 x 6 parts	M5 x 60 x 6 parts	M5 x 60 x 6 parts	M8 x 140 x 6 parts
Parts surpass of the fixing screw in relation to the circuit breaker	mm	10	8	15	15	15	18
Tightening torque - mounting (Nm)	Nm	1.5	1.5	3	3	3	6

Installation

DWB circuit breakers were designed to simplify installation on panels, as they can be fed from the top or bottom, without compromising the technical characteristics of the components.

Cable and bar connection to terminals

The connections to circuit breaker terminals must observe the following recommended limit:

		DWB160	DWB250	DWB400	DWB800	DWB1000	DWB1600		
Connection with cable	1 cable	Bare wire cord End terminal	Direct to round terminal lugs	Through round terminal lugs		Through round terminal lugs	Through round terminal lugs - up to 800 A only	Through round terminal lugs	
		Lug terminal	Through straight extension bar	Direct to the circuit breaker terminal ²⁾	Through straight extension bar	Direct to the circuit breaker terminal ²⁾	Through straight extension bar	Through straight extension bar	
	2 cables	Bare wire cord End terminal	Not recommended	Not recommended		Not recommended	Through round terminal lugs	Through round terminal lugs - up to 800 A only	Through round terminal lugs
		Lug terminal	Through straight extension bar	Through straight extension bar	Through straight extension bar	Through straight extension bar	Through straight extension bar	Through straight extension bar	Through straight extension bar
	3 and 4 cables	Bare wire cord End terminal	Not recommended	Not recommended		Not recommended	Not recommended	Not recommended	Through round terminal lugs
		Lug terminal	Through straight extension bar	Through straight extension bar	Through straight extension bar	Through straight extension bar	Through straight extension bar	Through straight extension bar	Through straight extension bar
	More than 4 cables	Bare wire cord End terminal	Not recommended	Not recommended		Not recommended	Not recommended	Not recommended	Not recommended
		Lug terminal	Through straight extension bar	Through straight extension bar	Through straight extension bar	Through straight extension bar	Through straight extension bar	Through straight extension bar	Through straight extension bar
	Connection with bar		Direct to the circuit breaker terminal	Direct to the circuit breaker terminal	Direct to the circuit breaker terminal	Direct to the circuit breaker terminal	Direct to the circuit breaker terminal	Direct to the circuit breaker terminal	Direct to the circuit breaker terminal
	Circuit breaker terminal screw		M6x17	M8x20	M8x25	M8x30	M8x30	M10x35 / M12x35	
Tightening tool		Allen#4	Allen#4	Allen#6	Allen#6	Allen#6	Allen#8 / Allen#10		

Notes: 1) The cross section of cables and bars must be observed, as well as the tightening torque informed in the product catalog.

2) Pay attention to the lug terminal size, comparing its dimension to the circuit breaker dimension. Some lug terminal models are bigger than the opening and depth of the circuit breaker terminal, and it is not possible to connect them directly to the circuit breaker terminal.

Examples of use

Direct connection of the lug terminal to the circuit breaker - 1 cable per terminal:

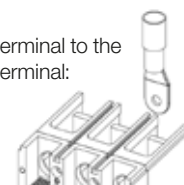

Direct cable connection by round terminal lugs

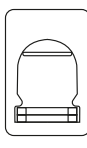
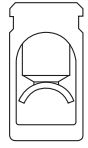
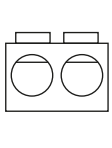
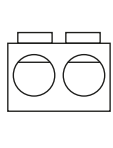
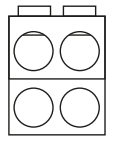
	DWB160	DWB250	DWB400	DWB800	DWB1000	DWB1600
Round terminal lugs schematic drawing						
Number of cables	Round terminal lugs for one cable	Round terminal lugs for one cable (accessory)	Round terminal lugs for one cable (accessory)	Round terminal lugs for two cables (accessory)	Round terminal lugs for two cables (accessory)	Round terminal lugs for four cables (accessory)
Maximum cable cross section (mm ²) ³⁾	70 / 50 ⁴⁾	120	240	240	240	240
Minimum cable cross section (mm ²) ³⁾	4	25	35	95	150	185
Cable length to be stripped to use terminal lugs (mm)	16	25	25	28	28	38
Tightening torque (N.m)	6	25	30	55	55	55

Notes: 3) Recommended cross sections for cables with stranding class 2, insulation of PVC - 70 °C, according to the NM NBR 280 standard (IEC 60228).

4) Maximum cross section with cord end terminal.

Direct connection to the circuit breaker bar

Quantity	DWB160	DWB250	DWB400	DWB800	DWB1000	DWB1600
Maximum width (mm)	10	20	20	50	50	50
Maximum thickness (mm)	7	6	12	13	13	20
Tightening torque (N.m)	6	8	20	20	20	30 (M10) / 50 (M12)

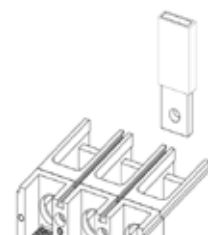

Installation

Use of phase barrier and terminal cover

The connections to the circuit breaker terminals must observe the following recommended limit:

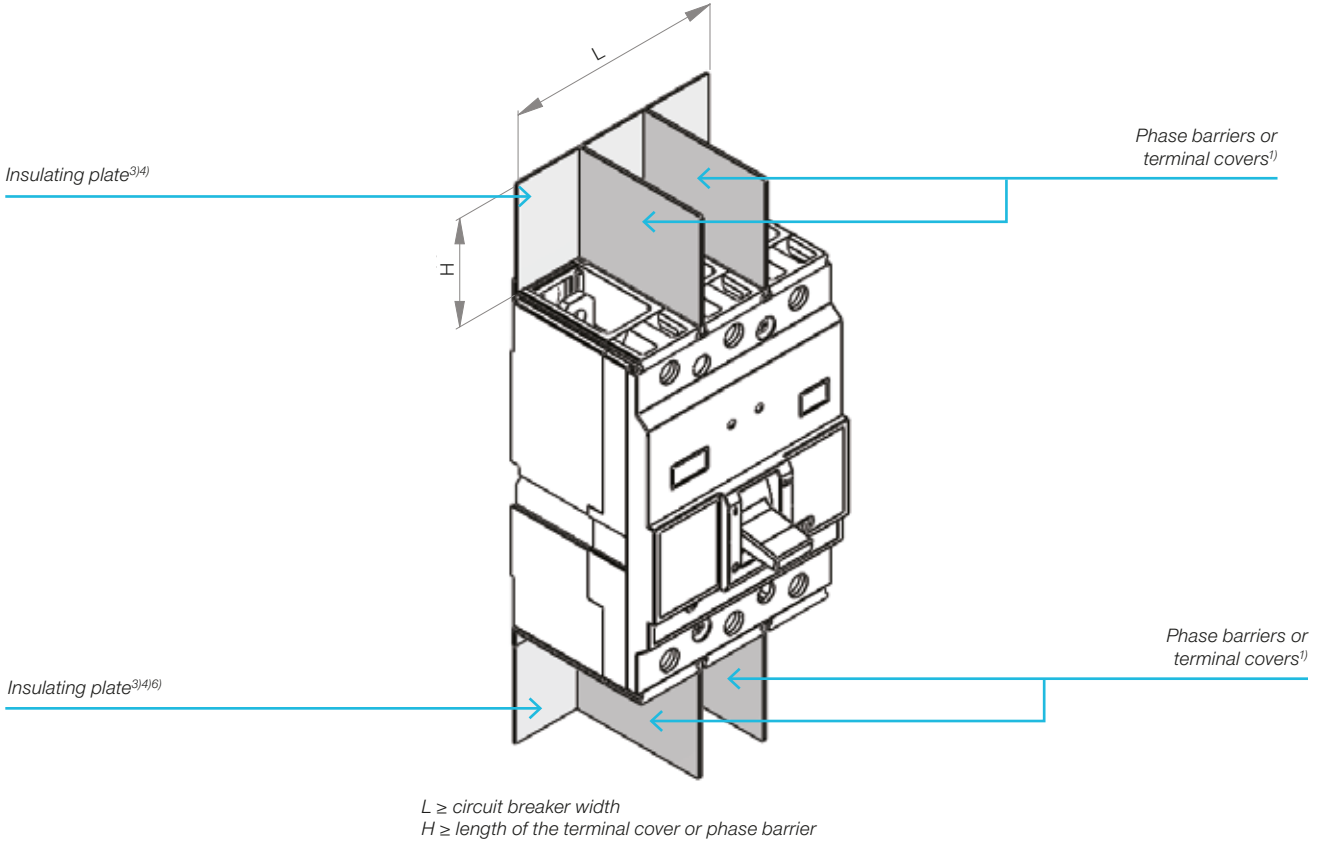

		Ue <500 V		Ue ≥500 V	
		Input	Output	Input	Output
Connection with cable	Bare wire/cord end terminal	Mandatory use of phase barrier ¹⁾ or terminal cover	Optional use of phase barrier ¹⁾ or terminal cover	Mandatory use of phase barrier ¹⁾ or terminal cover	Mandatory use of phase barrier ¹⁾ or terminal cover
	Lug terminal	Mandatory use of phase barrier ¹⁾ or terminal cover	Optional use of phase barrier ¹⁾ or terminal cover	Mandatory use of phase barrier ¹⁾ or terminal cover	Mandatory use of phase barrier ¹⁾ or terminal cover
Connection with insulated bar		Mandatory use of phase barrier ¹⁾ or terminal cover	Optional use of phase barrier ¹⁾ or terminal cover	Mandatory use of phase barrier ¹⁾ or terminal cover	Mandatory use of phase barrier ¹⁾ or terminal cover
Connection with 90° connection extension bars ²⁾		Mandatory use of protection cover	Mandatory use of protection cover	Mandatory use of protection cover	Mandatory use of protection cover
Insulating plate ³⁾⁽⁴⁾⁽⁵⁾		Optional	Optional	Mandatory	Mandatory

Notes: 1) 2 phase barriers are supplied on DWB160, DWB250 and DWB400 circuit breakers. When two more barriers are necessary, those parts are sold as accessory.

2) Protection cover supplied with the 90° connection extension bars DWB circuit breaker. For DWB1600, use the terminal cover included in the product.

3) Not supplied with the molded case circuit breakers. It must be produced by the user.

4) Minimum characteristics requirements of the material to be used as insulating plate: Dielectric strength ≥ 12 kV/mm. Material not propagating flame.

Recommended material: phenolite, polycarbonate.

5) Installation according to the figure above.

6) Insulating plate already included in circuit breaker DWB1600.

Deratings

Altitude derating

Application of circuit breakers in altitude		
Altitude (m)	Derating for the rated current I_n	Maximum rated operating voltage U_g (V)
2000	1	1
3000	0.98	0.88
4000	0.93	0.78
5000	0.90	0.68

Temperature derating

	10 °C	15 °C	20 °C	25 °C	30 °C	35 °C	40 °C	45 °C	50 °C	55 °C	60 °C
DWB160	1.20	1.16	1.13	1.10	1.06	1.05	1.03	1.00	0.98	0.94	0.91
DWB250	1.18	1.16	1.13	1.10	1.08	1.05	1.02	1.00	0.98	0.94	0.90
DWB400	1.18	1.16	1.13	1.10	1.08	1.05	1.02	1.00	0.98	0.94	0.90
DWB800	1.19	1.17	1.14	1.12	1.09	1.06	1.03	1.00	0.97	0.94	0.91
DWB1000	1.00	1.00	1.00	1.00	1.00	1.00	1.00	1.00	0.95	0.90	0.80
DWB1600	1.00	1.00	1.00	1.00	1.00	1.00	1.00	1.00	0.95	0.90	0.80

Notes: The recommended temperature refers to the place where the circuit breaker is installed.
Apply the recommended derating to the rated current of the relevant circuit breaker.



Thermal dissipation

Circuit protection

DWB160	I_n (A)	16	20	25	32	40	50	63	70	80	90	100	110	125	150	160
	Thermal dissipation (W/pole)	1	1	2	4	4	5	8	4	5	6	7	7	10	11	12
DWB160L	I_n (A)	16	20	25	32	40	50	63	70	80	90	100	110	125		
	Thermal dissipation (W/pole)	1	1	2	4	4	6	10	5	7	9	11	12	15		
DWB250	I_n (A)	100	125	160	200	250										
	Thermal dissipation (W/pole)	14	19	17	14	20										
DWB250L	I_n (A)	100	125	160	200											
	Thermal dissipation (W/pole)	17	24	25	26											
DWB400	I_n (A)	200	250	320	400											
	Thermal dissipation (W/pole)	14	20	19	30											
DWB800	I_n (A)	320	400	500	630	800										
	Thermal dissipation (W/pole)	19	30	38	47	47										
DWB1000	I_n (A)	500	630	800	1000											
	Thermal dissipation (W/pole)	16	25	40	63											
DWB1600	I_n (A)	1250	1600													
	Thermal dissipation (W/pole)	51	96													

Motor protection

DWB160	I_n (A)	25	32	40	50	65	80	95
	Thermal dissipation (W/pole)	2	4	4	5	6	7	7
DWB160L	I_n (A)	25	32	40	50	65	80	95
	Thermal dissipation (W/pole)	2	4	4	6	8	9	9
DWB250	I_n (A)	80	95	105	125	150	185	200
	Thermal dissipation (W/pole)	2	3	3.5	5	7	10.5	12
DWB250L	I_n (A)	80	95	105	125	150	185	200
	Thermal dissipation (W/pole)	4	5.5	7	9.5	13.5	21	24
DWB400	I_n (A)	150	185	250	320			
	Thermal dissipation (W/pole)	14	14	20	19			
DWB800	I_n (A)	420	500					
	Thermal dissipation (W/pole)	32	38					
DWB1600	I_n (A)	1,000						
	Thermal dissipation (W/pole)	33						

Generator protection

DWB160	I_n (A)	55	75	85	105	125	140	160
	Thermal dissipation (W/pole)	7	5	6	7	10	11	12
DWB250	I_n (A)	105	125	160	200	250		
	Thermal dissipation (W/pole)	14	19	17	14	20		
DWB400	I_n (A)	200	250	320	400			
	Thermal dissipation (W/pole)	14	20	19	30			
DWB800	I_n (A)	320	400	500	630	800		
	Thermal dissipation (W/pole)	19	30	38	47	47		
DWB1600	I_n (A)	1,250	1,600					
	Thermal dissipation (W/pole)	51	96					

Characteristic curves - $I \times t$

DWB160_D (distribution)

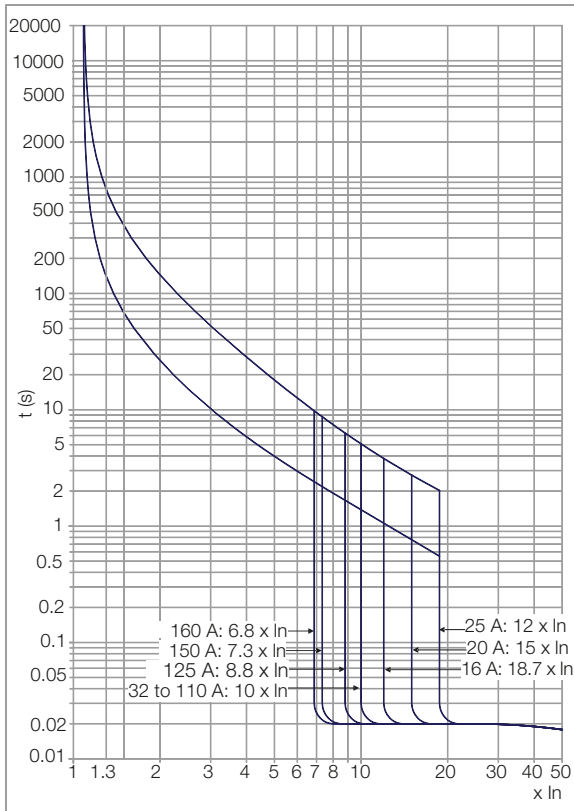

DWB160_G (generator)

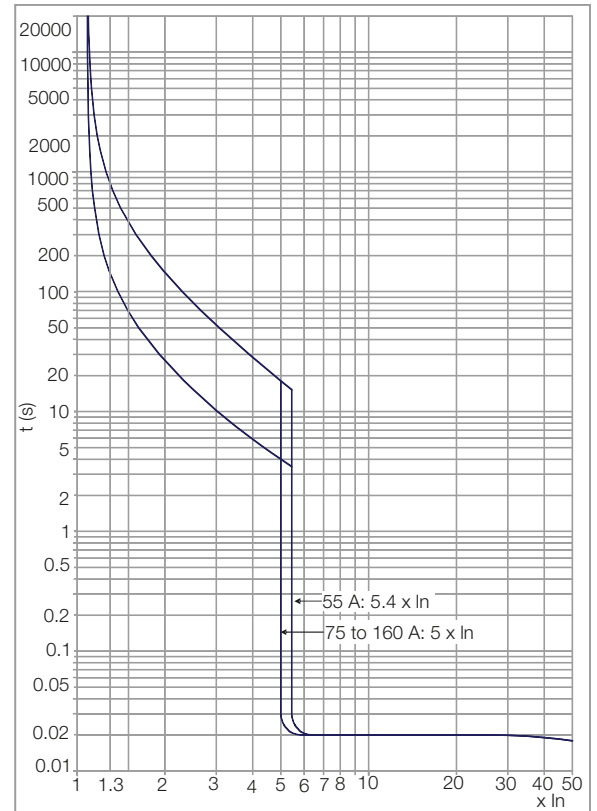

DWB160_M (motor)

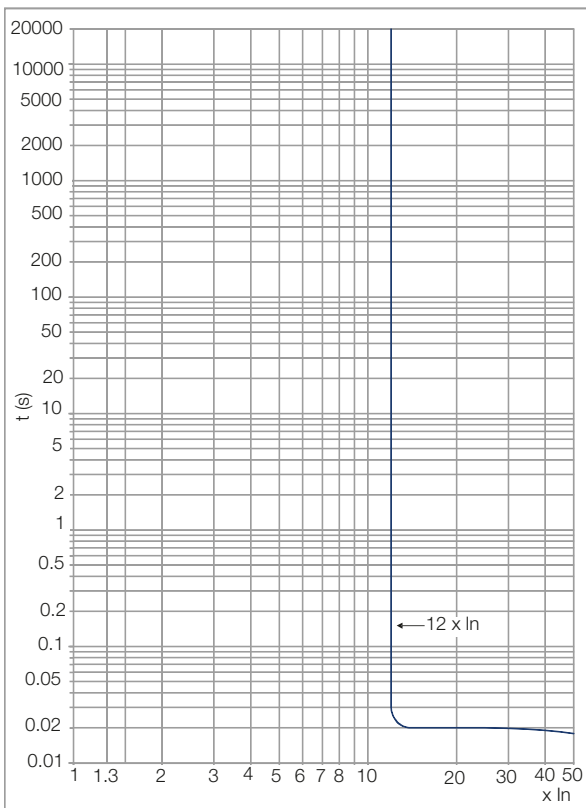

Characteristic curves - I x t

DWB250_D (distribution)

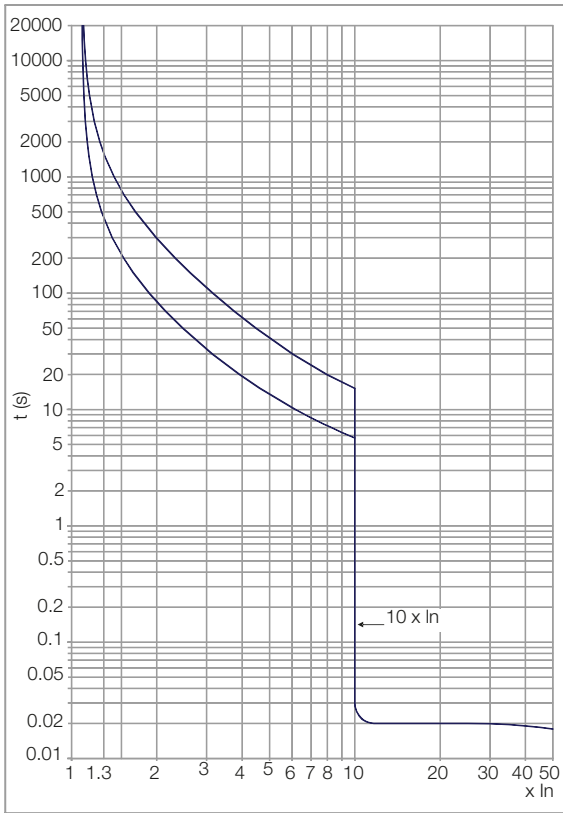

DWB250_G (generator)

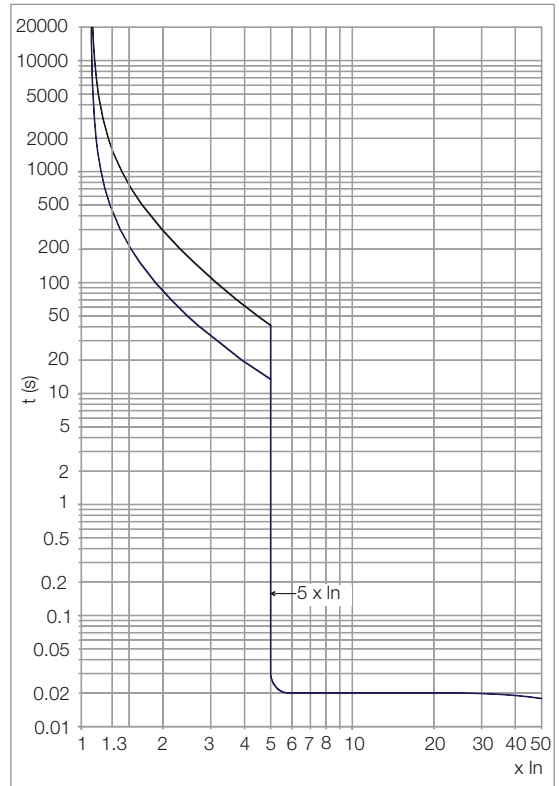

DWB250_M (motor)

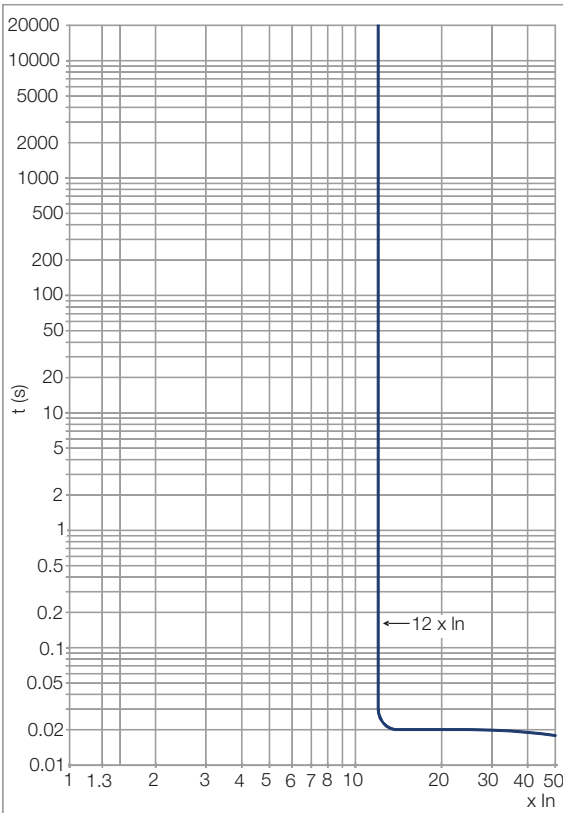

Characteristic curves - I x t

DWB400_D (distribution)

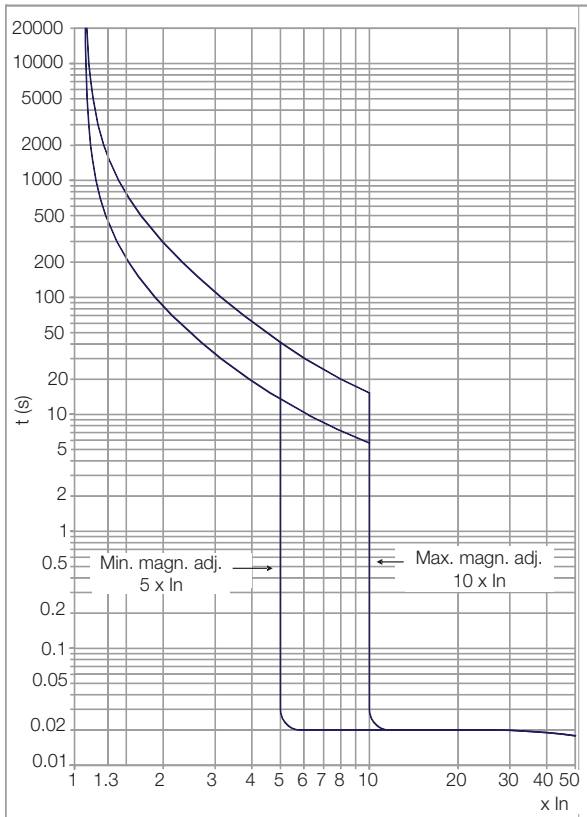

DWB400_G (generator)

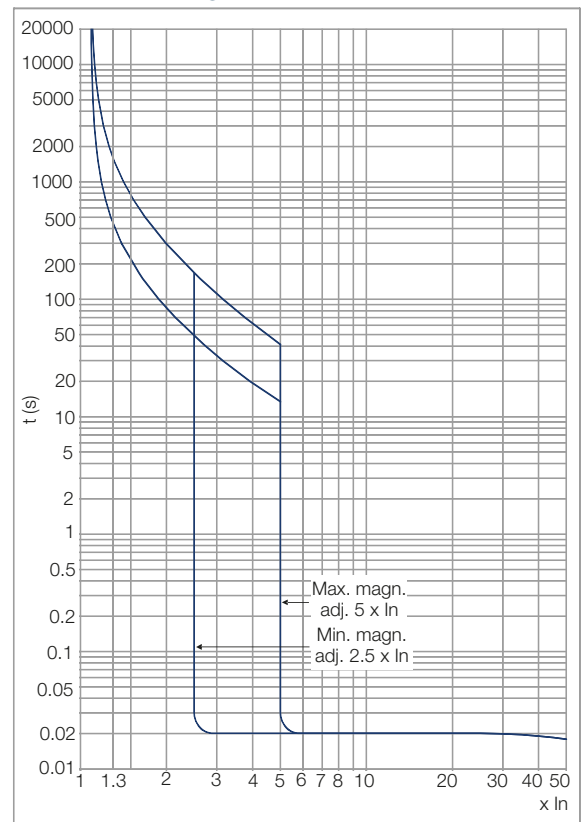

DWB400_M (motor)

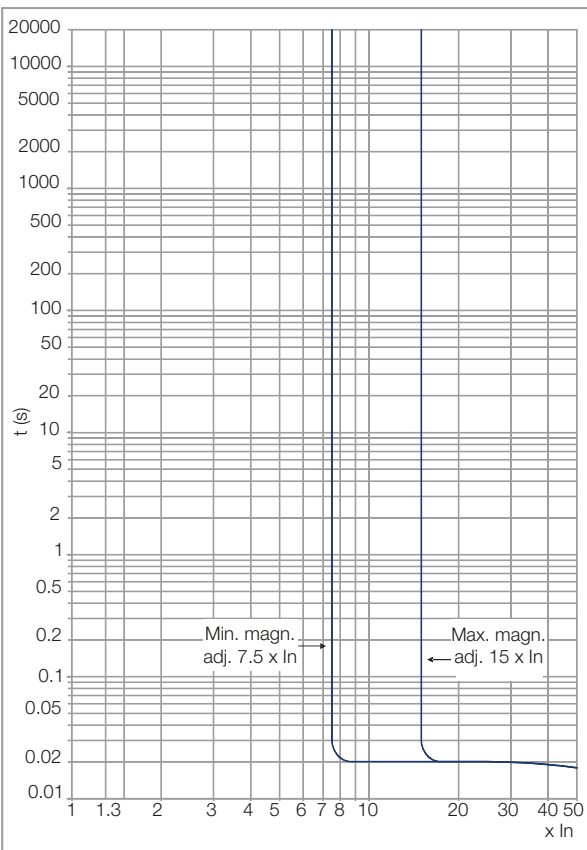

Characteristic curves - I x t

DWB800 (distribution)

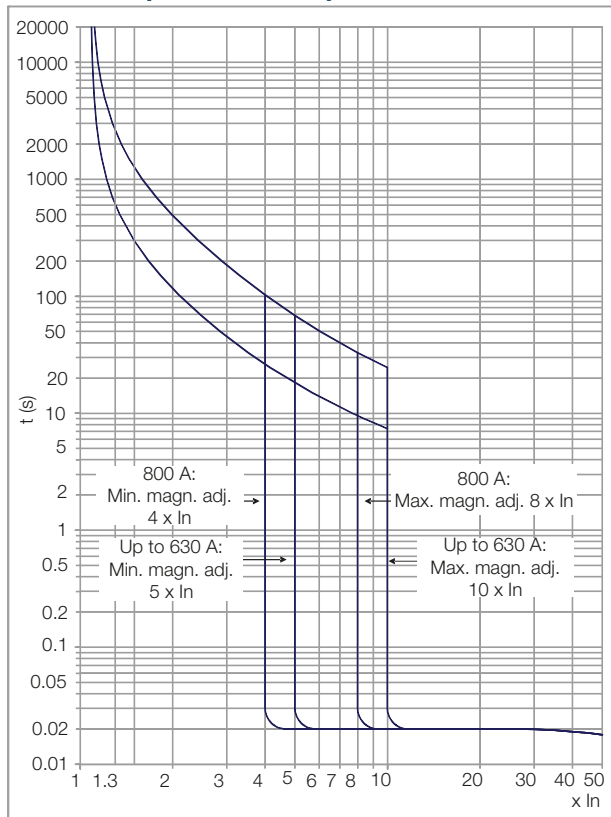

DWB800 (generator)

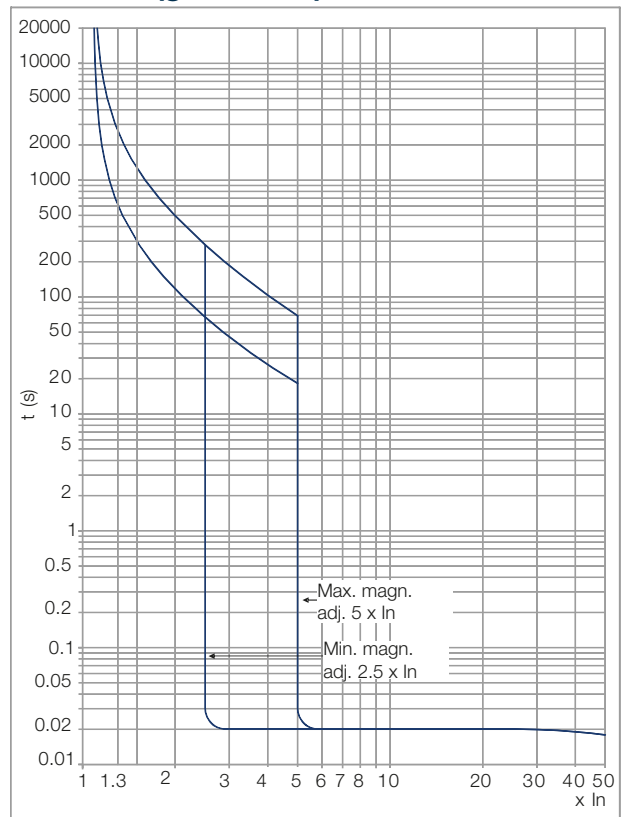

DWB800 (motor)

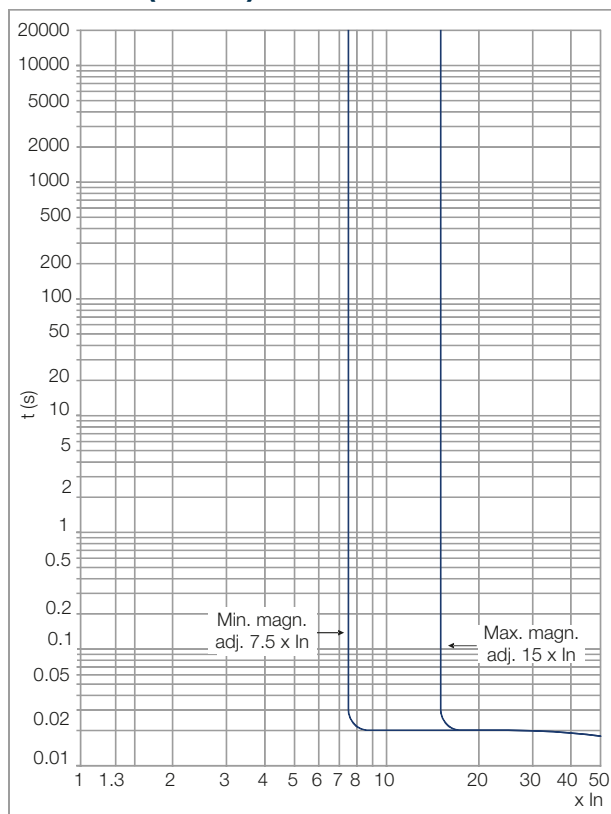

Characteristic curves - I x t

DWB1000 (distribution and generator) - overload protection (L and S)

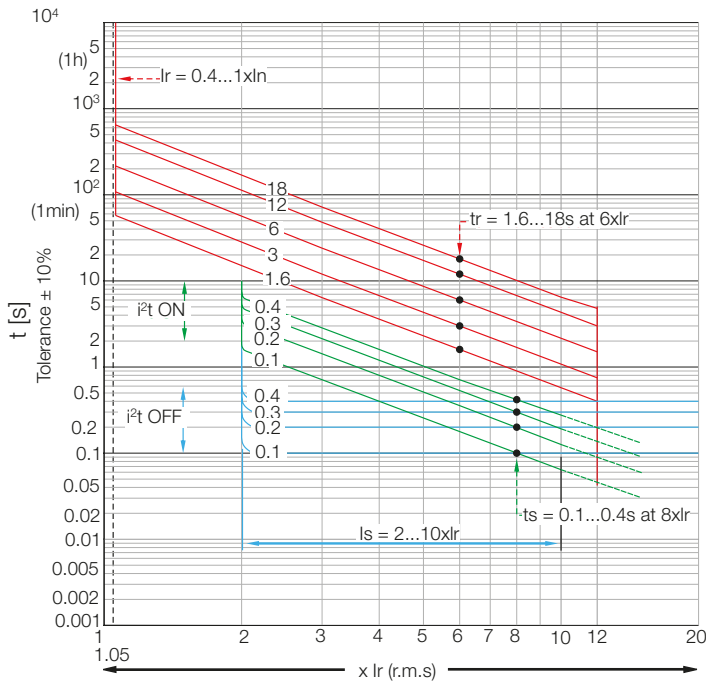

Note: the DWB1000 can be used for the protection of both electric circuits and generators.

DWB1000 (distribution and generator) - short circuit protection (I - instantaneous)

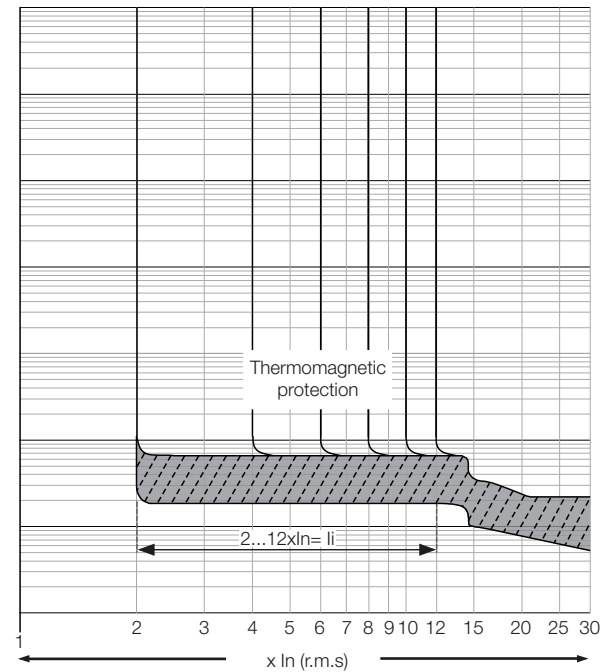

Characteristic curves - I x t

DWB1600 (distribution and generator) - overload protection (L and S)

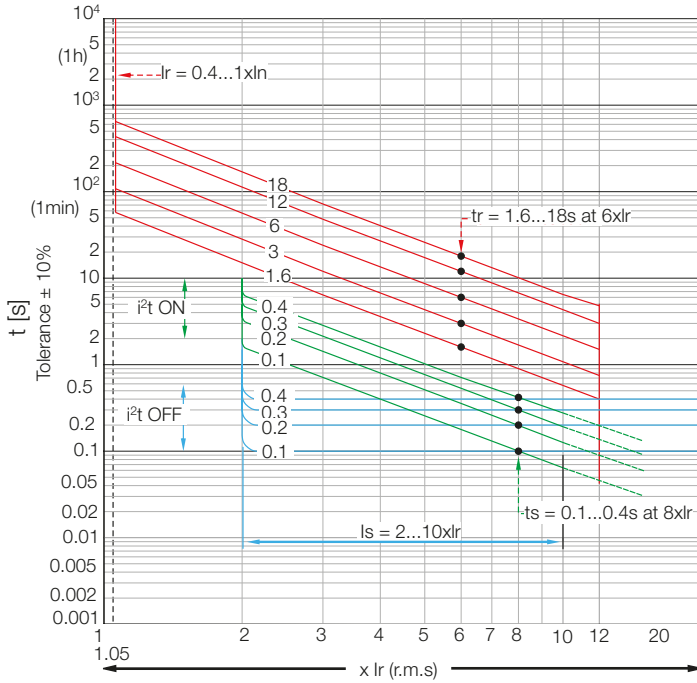

DWB1600 (distribution and generator) - Short circuit protection (I - instantaneous)

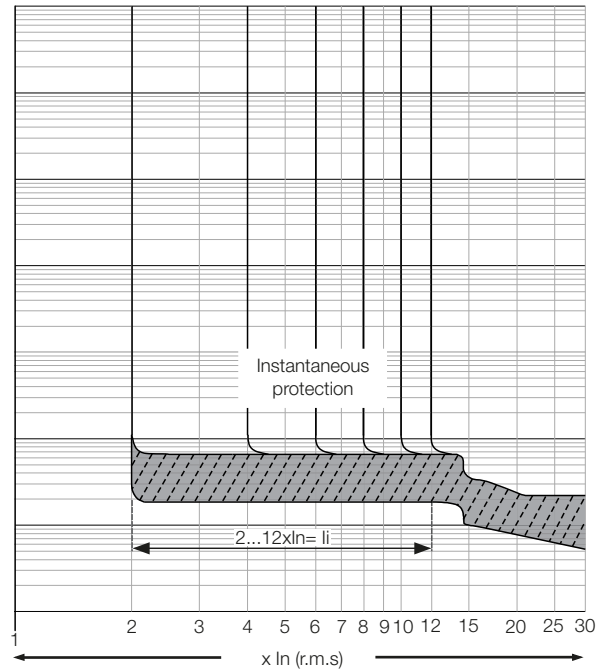

DWB1600 (Motor)

DWB1600 - short circuit protection (I - instantaneous)

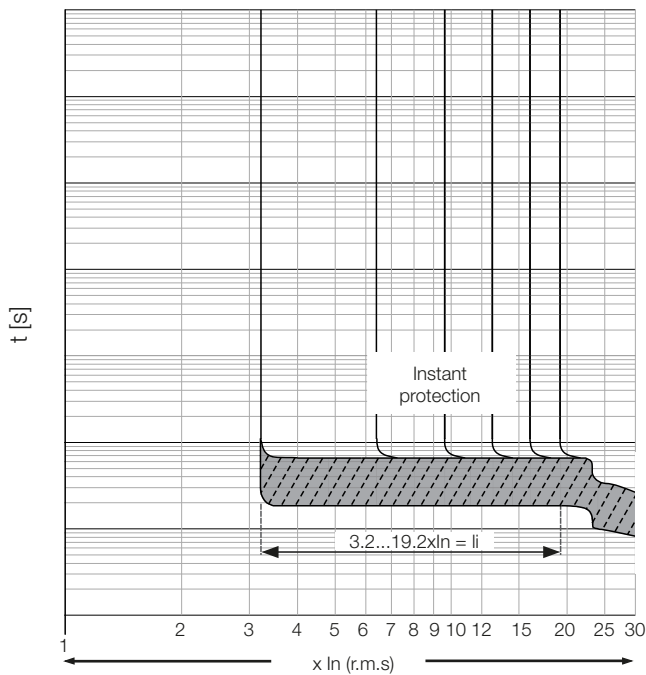

Short circuit limiting characteristic curve

380/415 V ac

DWB160 B/N

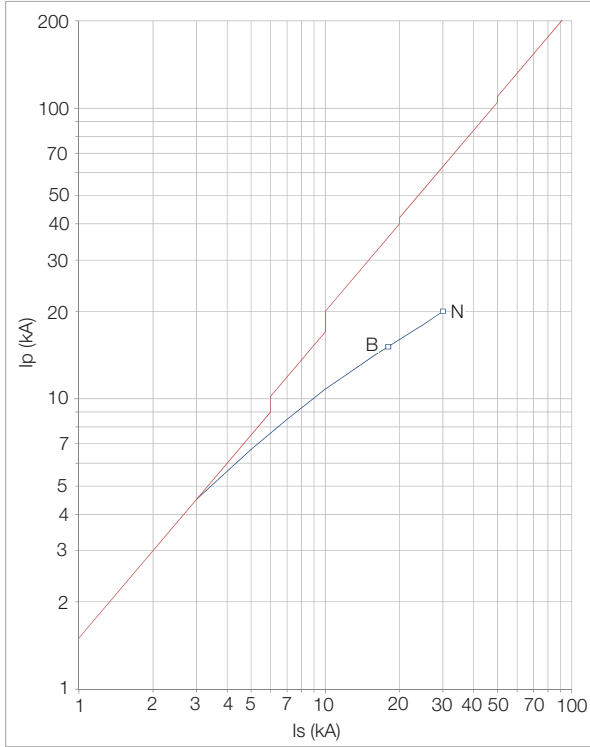

DWB160 L

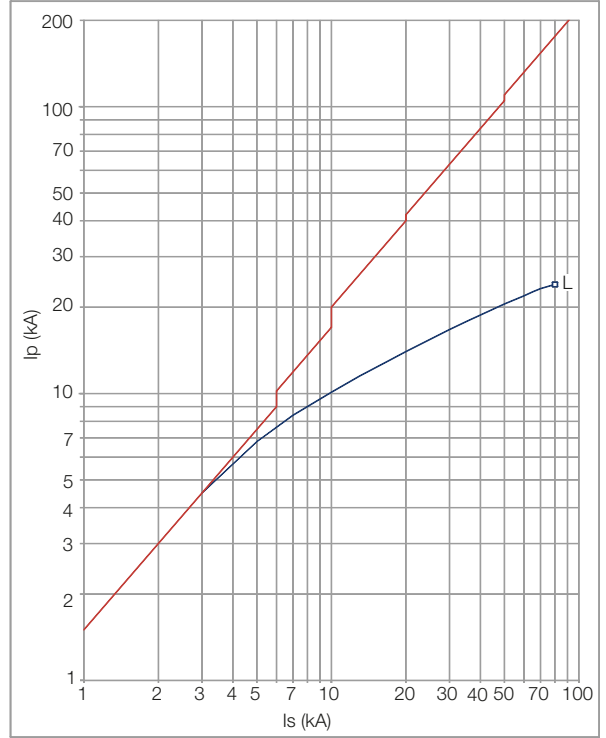

DWB250 B/N

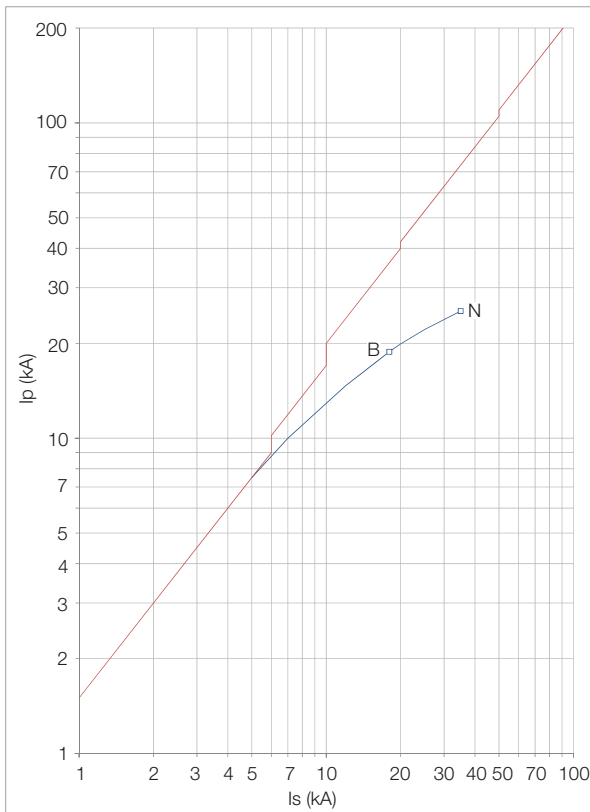

DWB250 L

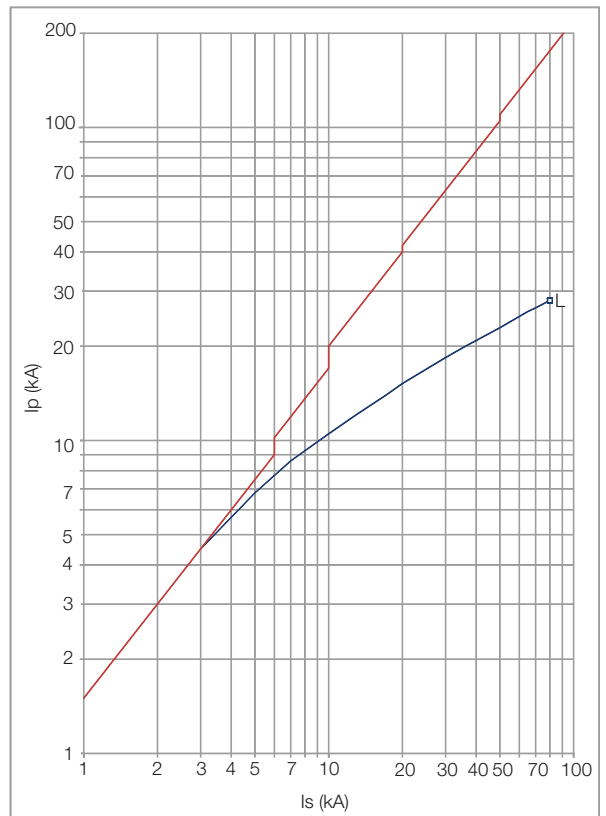

Short circuit limiting characteristic curve

380/415 V ac

DWB400

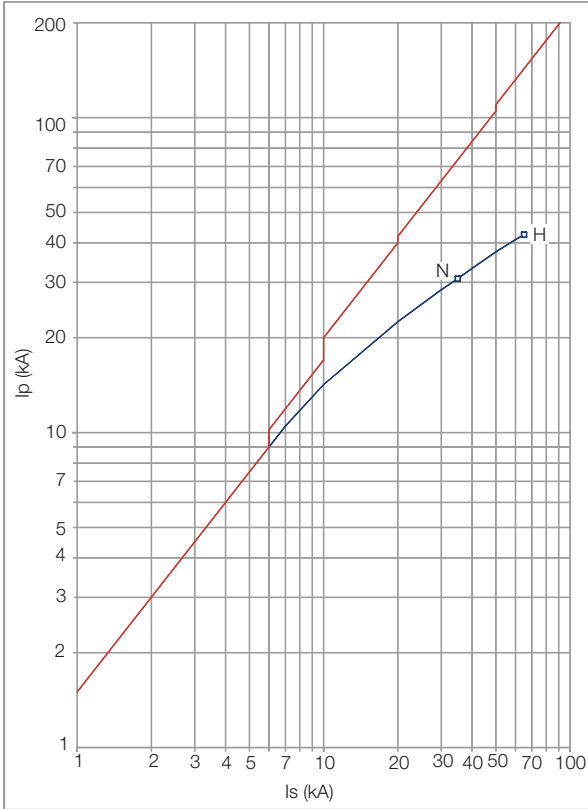

DWB800

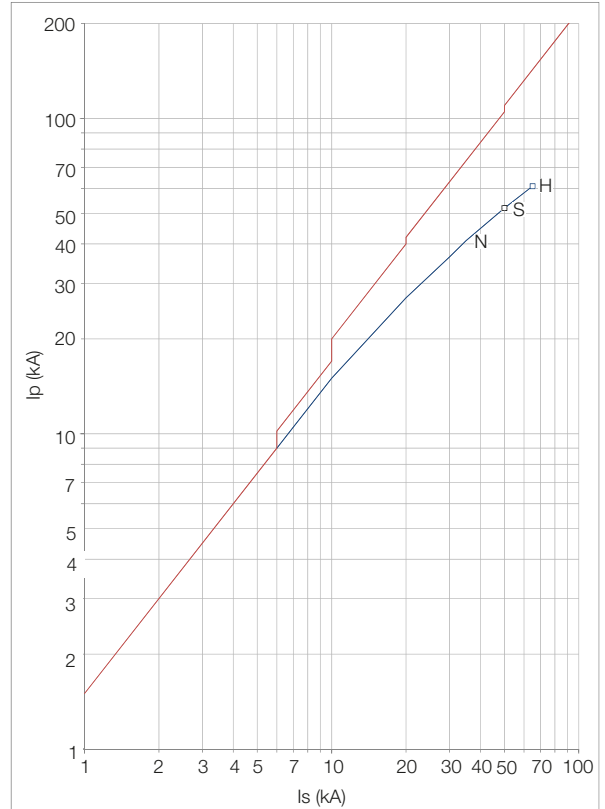

DWB1000

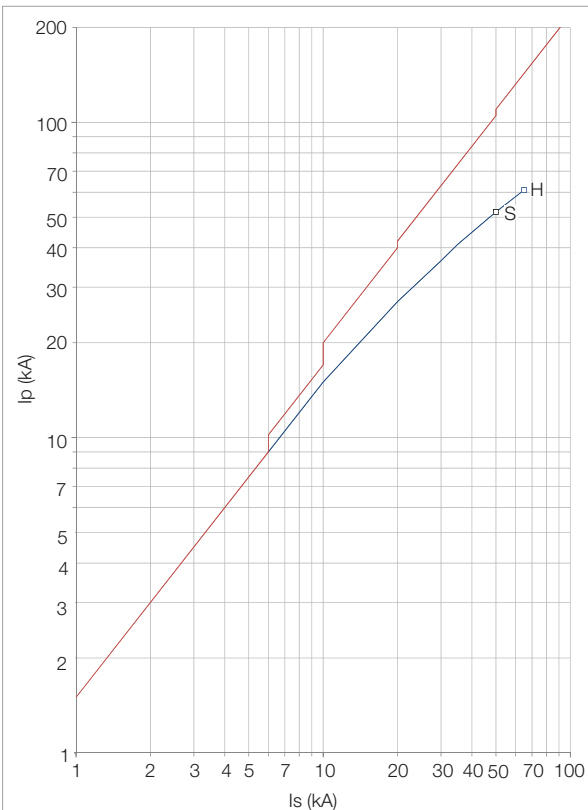

DWB1600

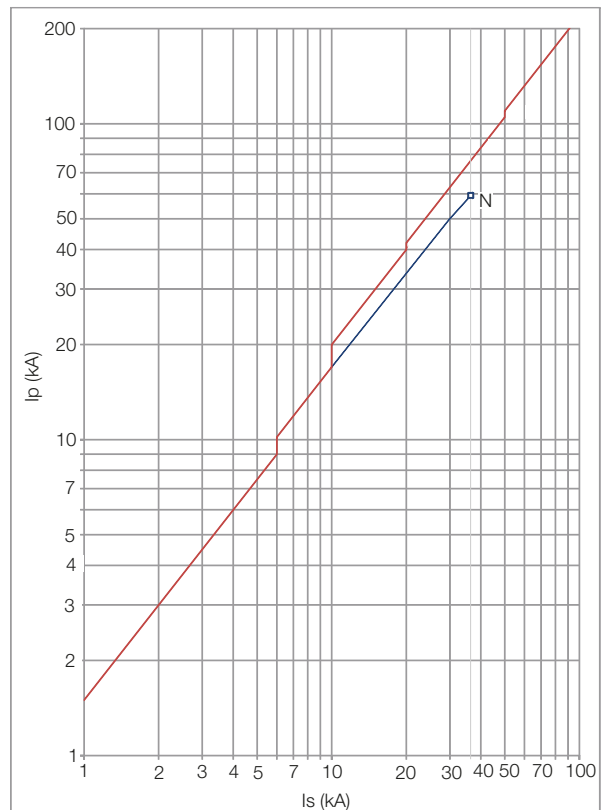

Dimensions

Circuit breakers

DWB160 B/N – 3P

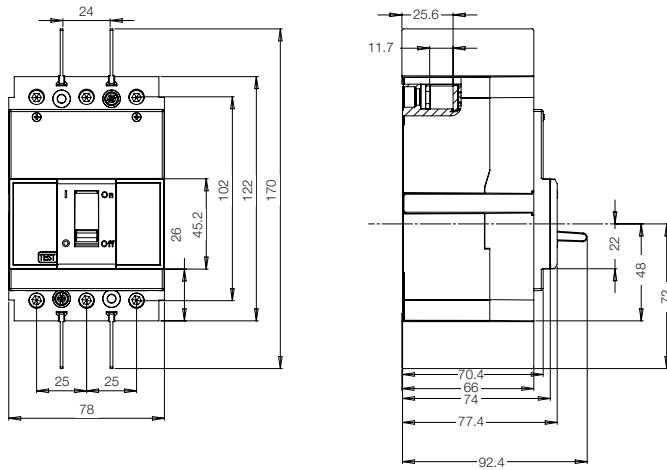

DWB160 L

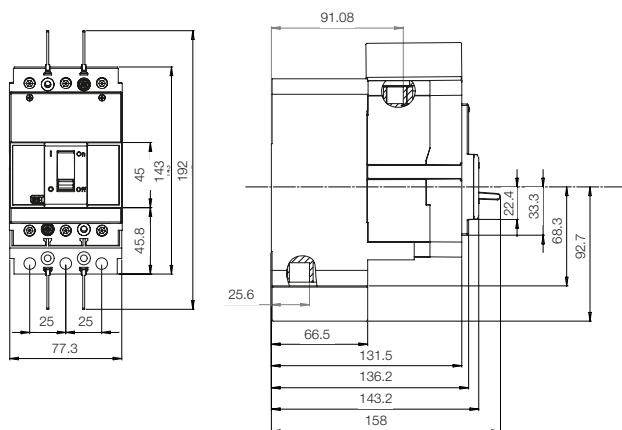

DWB160 B – 4P

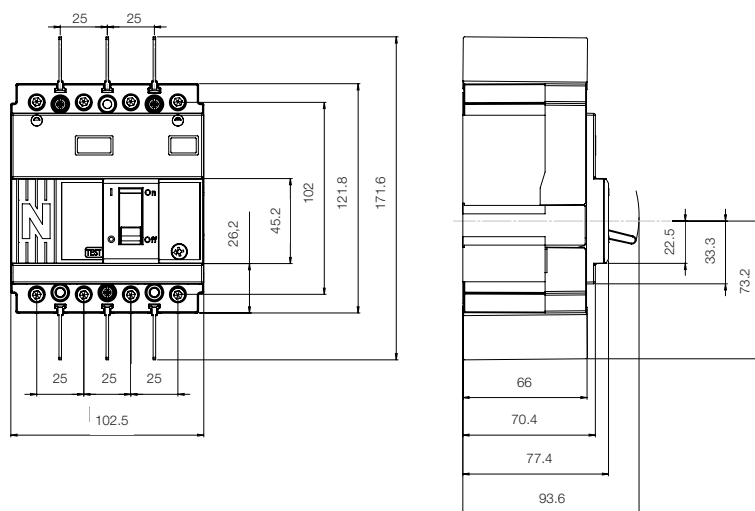

Notes: For connection dimensions with busbars see the "Direct Busbar Connection to Breaker" table.
Dimensions in millimeters.

Dimensions

Circuit breakers

DWB250 N/B - 3P

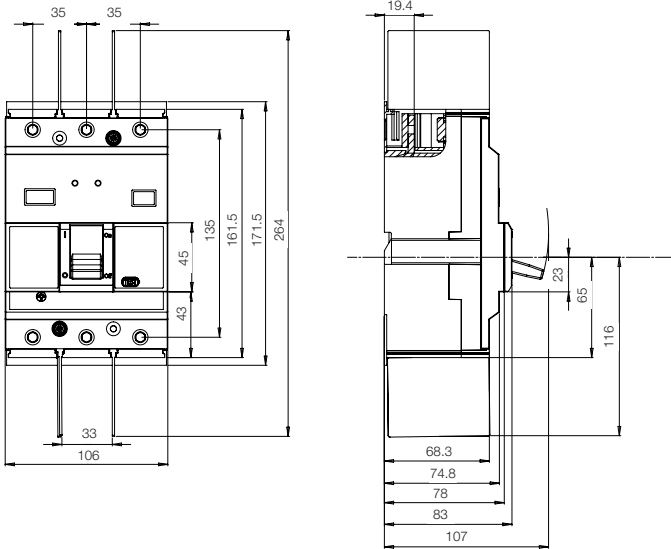

DWB250 L

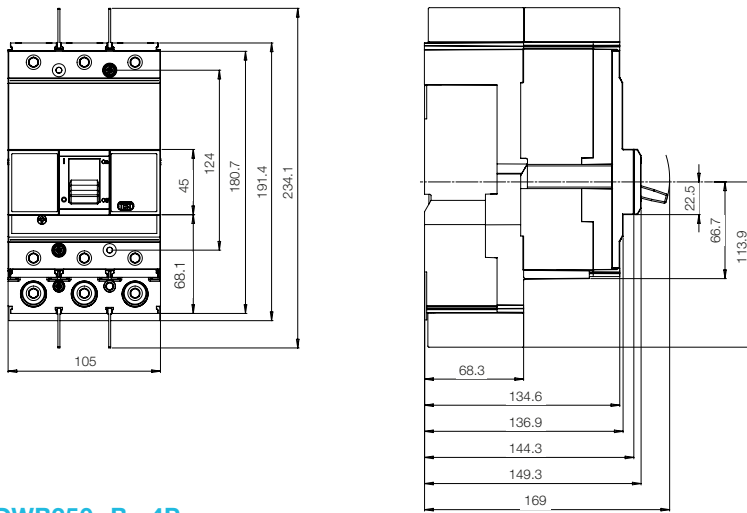

DWB250- B - 4P

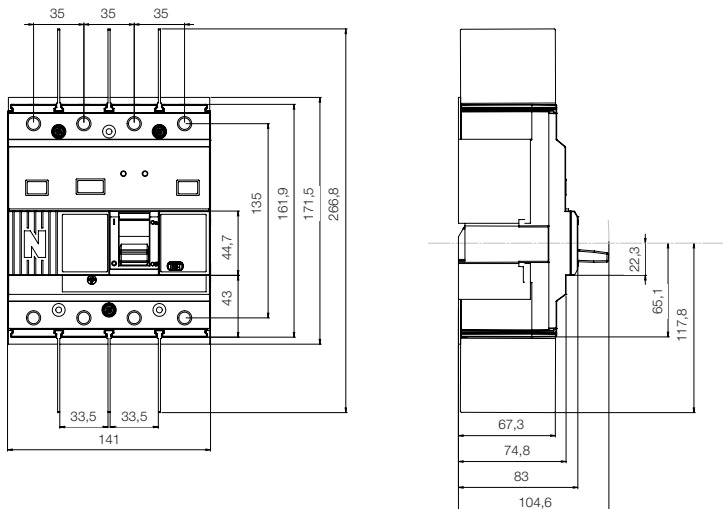

Notes: For connection dimensions with busbars see the "Direct Busbar Connection to Breaker" table. Dimensions in millimeters.

Dimensions

Circuit breakers

DWB800 – 3P

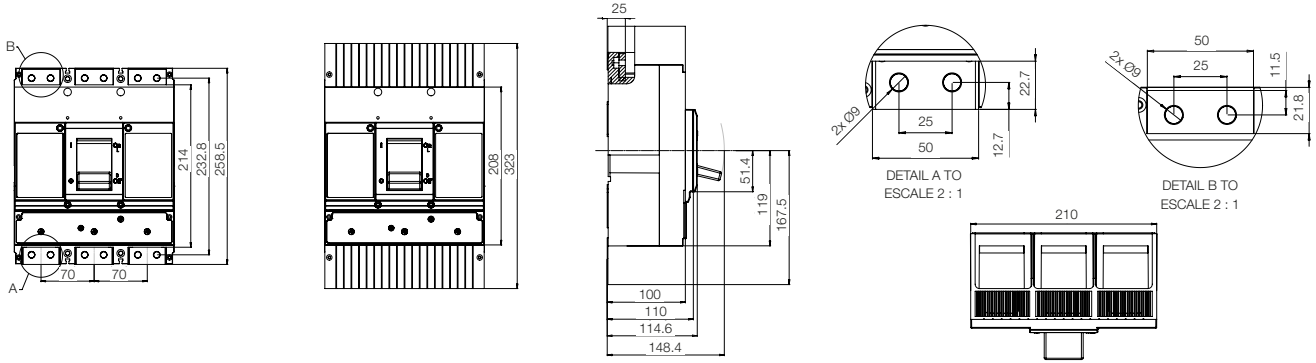

DWB800 – 4P

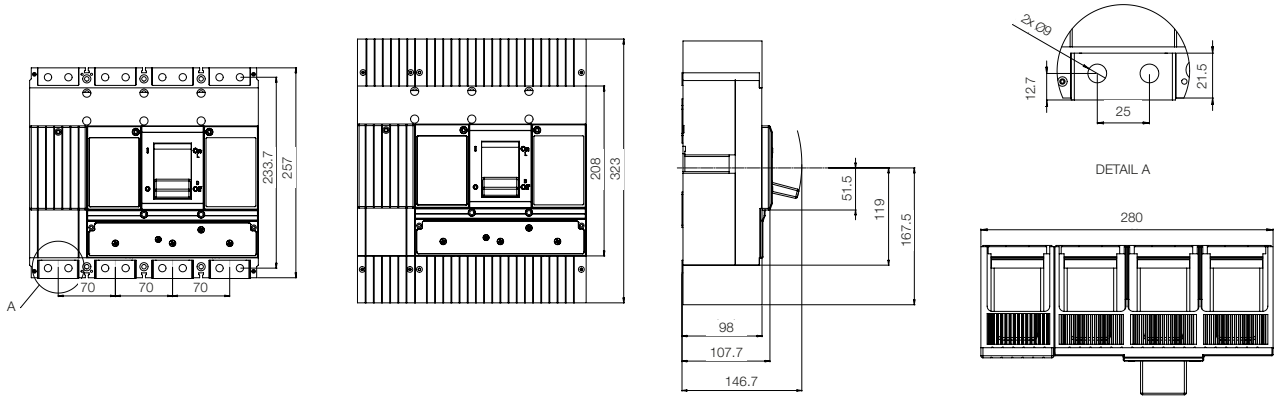

Note: dimensions in millimeters.

Dimensions

Circuit breakers

DWB1000 – 3P

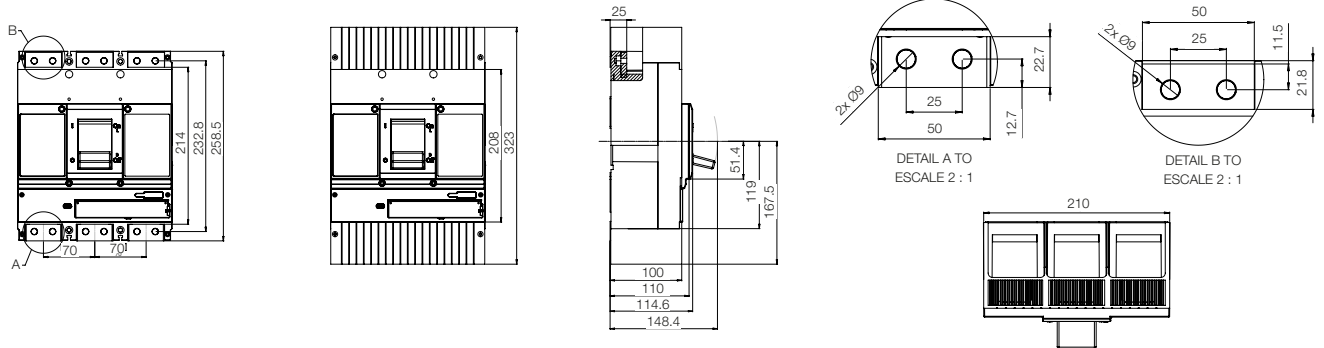

DWB1000 – 4P

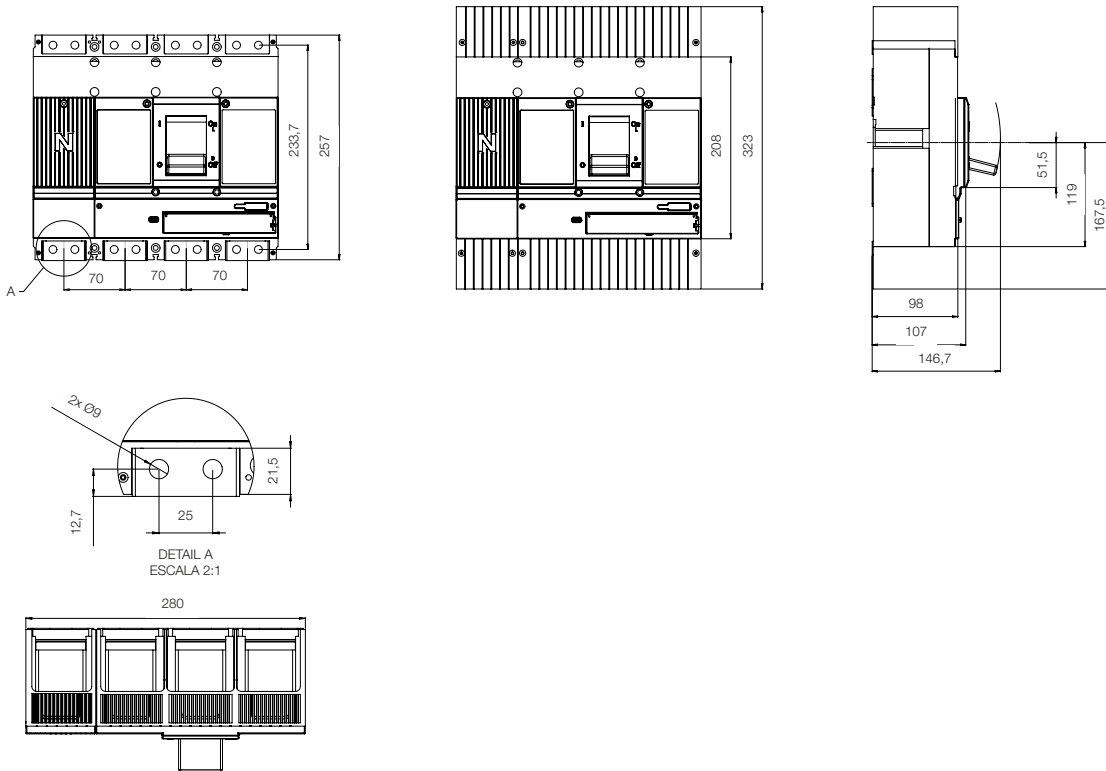

Note: dimensions in millimeters.

Dimensions

Circuit breakers

DWB1600 / DWM1600 – 3P

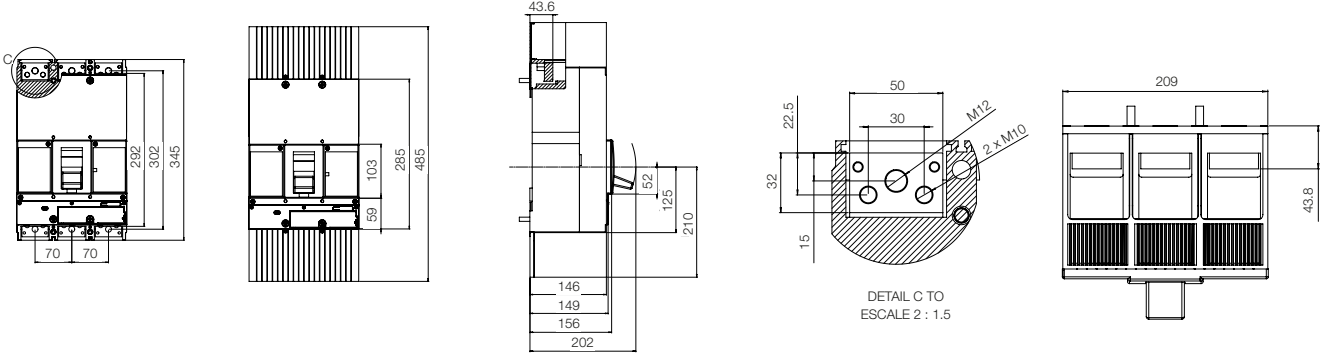

DWB1600 – 4P

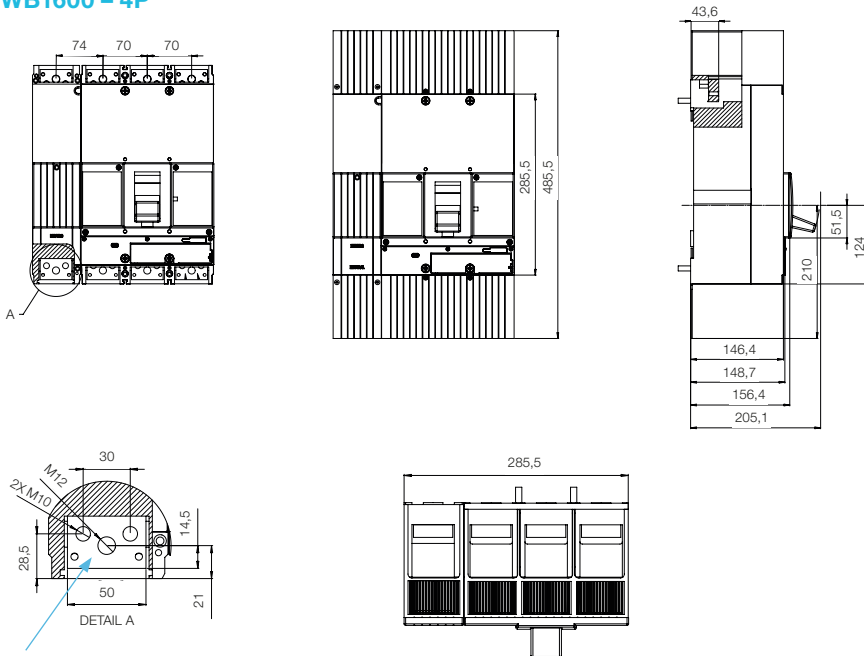

Bar thickness:

- In de 1,250 A = 12 mm
- In de 1,600 A = 16 mm

Note: dimensions in millimeters.

Dimensions

Accessories

MP - escutcheons

MP DWB160

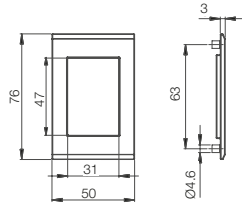

MP DWB250

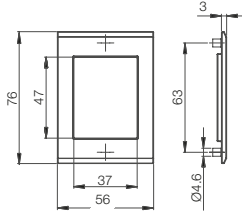

MP DWB400

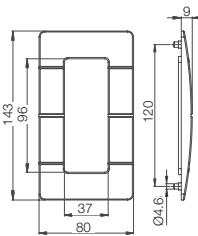

MP DWB800 / DWB1000 / DWB1600

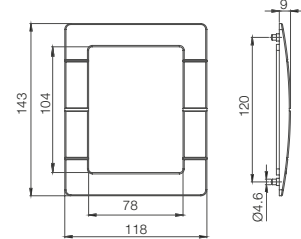

BE - straight extension bars

**Frame 160 3P +
BE DWB160 3P**

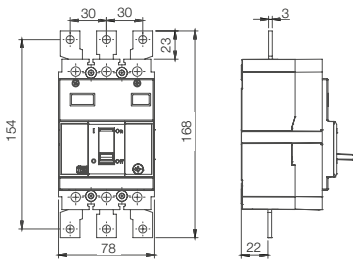

**Frame 250 3P +
BE DWB250 3P**

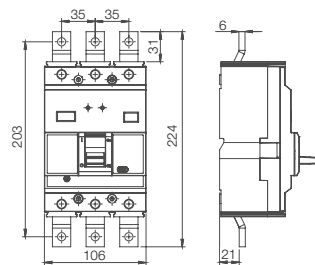

**Frame 400 3P +
BE DWB400 3P**

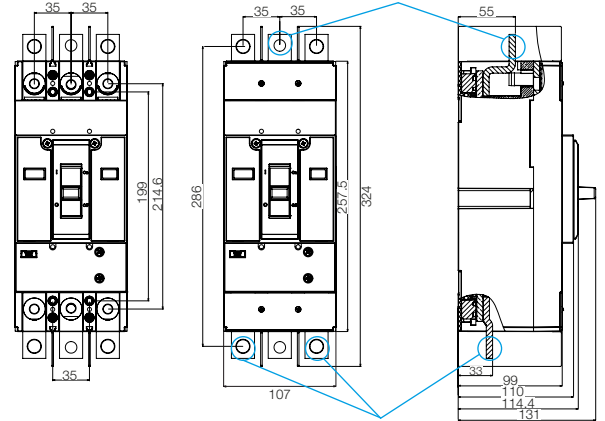

**Frame DWB800-1000 3P +
BE DWB800-1000**

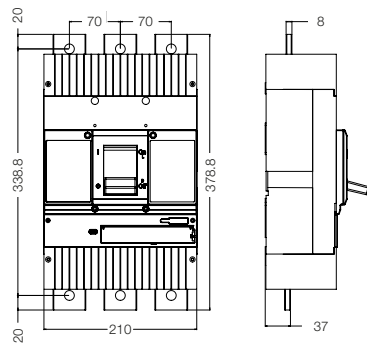

**Frame 1600 3P +
BE DWB1600**

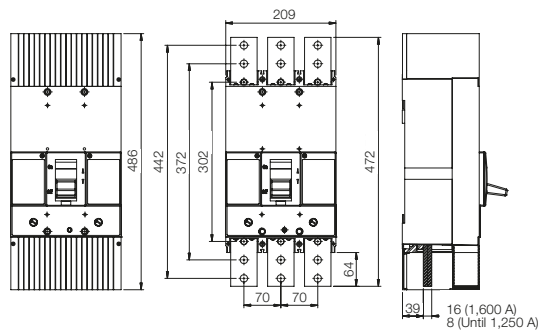

Note: dimensions in millimeters.

Dimensions

Panel door operating handle

MRXS - DWB160 - DWB250

MRXL - DWB160 - DWB250 - DWB400

MRXL - DWB800 - DWB1000 - DWB1600

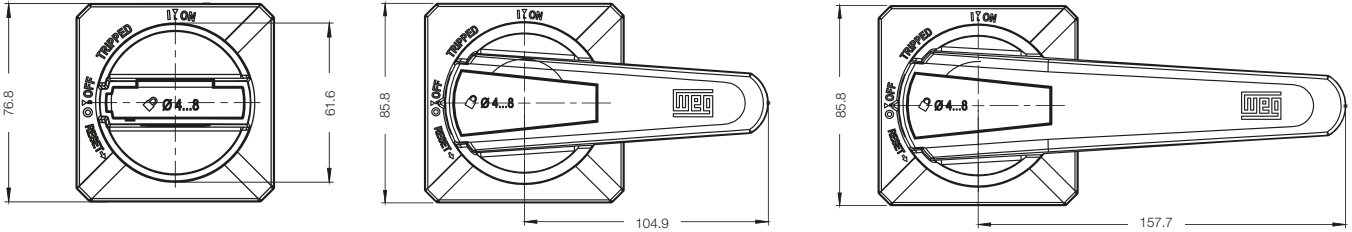

Accessories

MRXS - panel door operating handle

Frame 160 3P/4P + MRXS DWB160 (B and N versions)

Panel door cutout

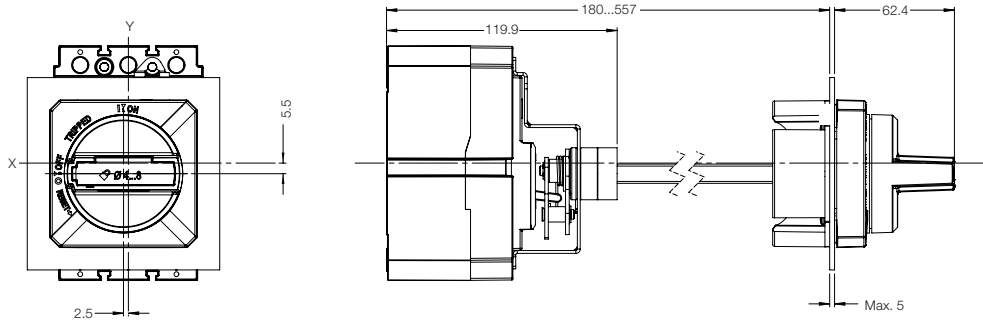

Frame 250 3P/4P + MRXS DWB250 (B and N versions)

Panel door cutout

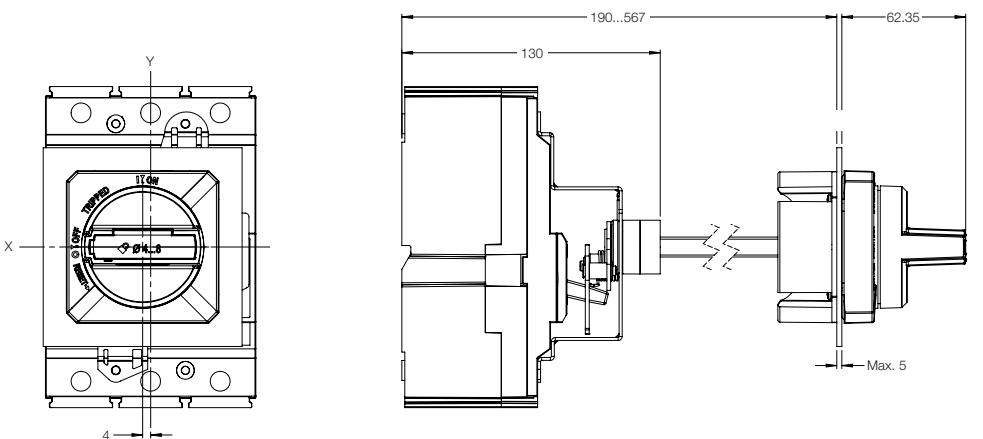

Note: dimensions in millimeters.

Dimensions

Accessories

MRXS - panel door operating handle

Frame 160 3P/4P + MRXS DWB160 (L version)

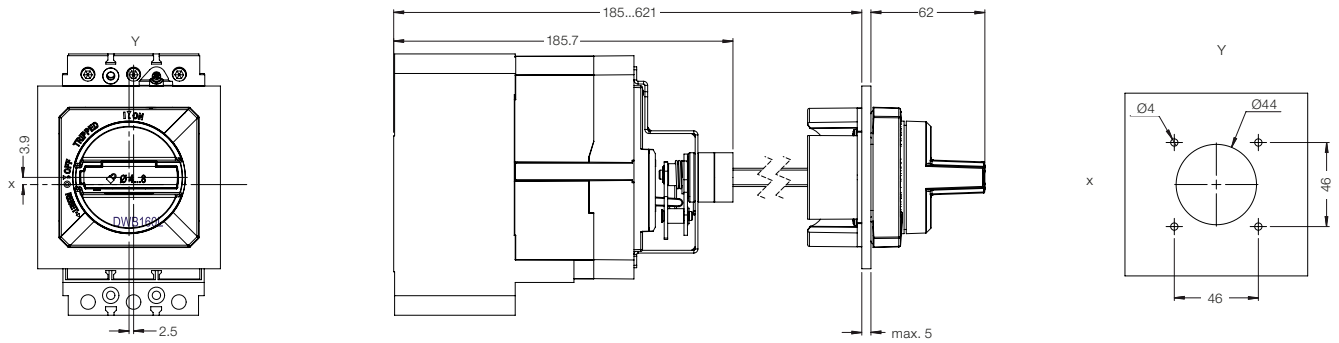

Frame 250 3P/4P + MRXS DWB250 (L version)

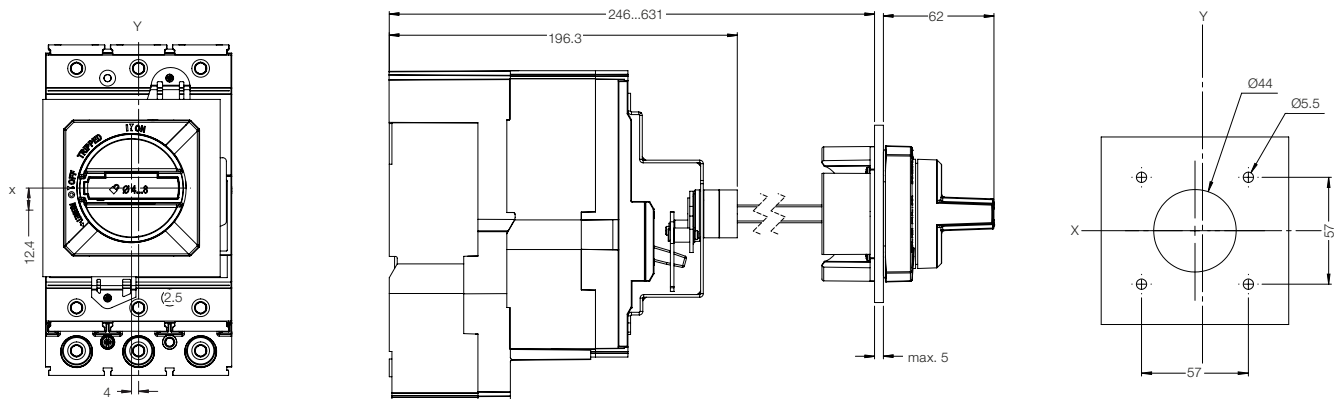

Note: dimensions in millimeters.

Dimensions

Accessories

MRXL - panel door operating handle

Frame 160 3P/4P + MRXL DWB160 (B and N versions)

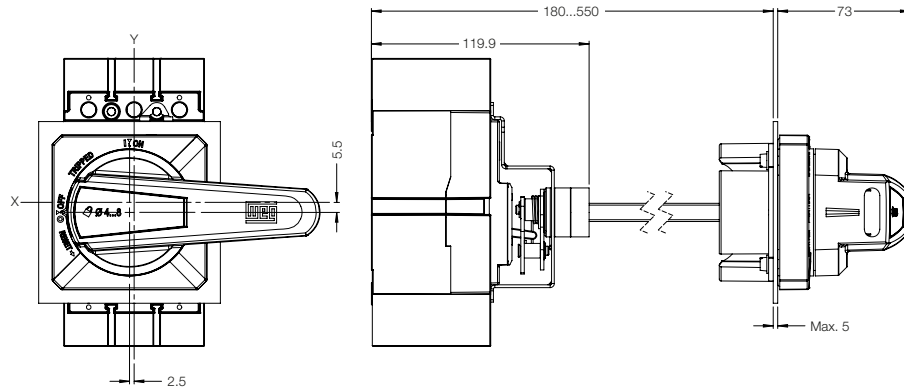

Panel door cutout

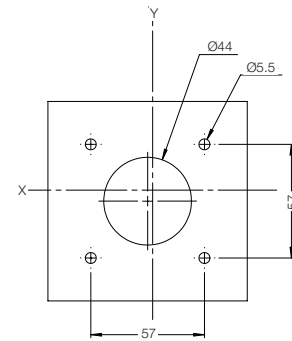

Frame 250 3P/4P + MRXL DWB250 (B and N versions)

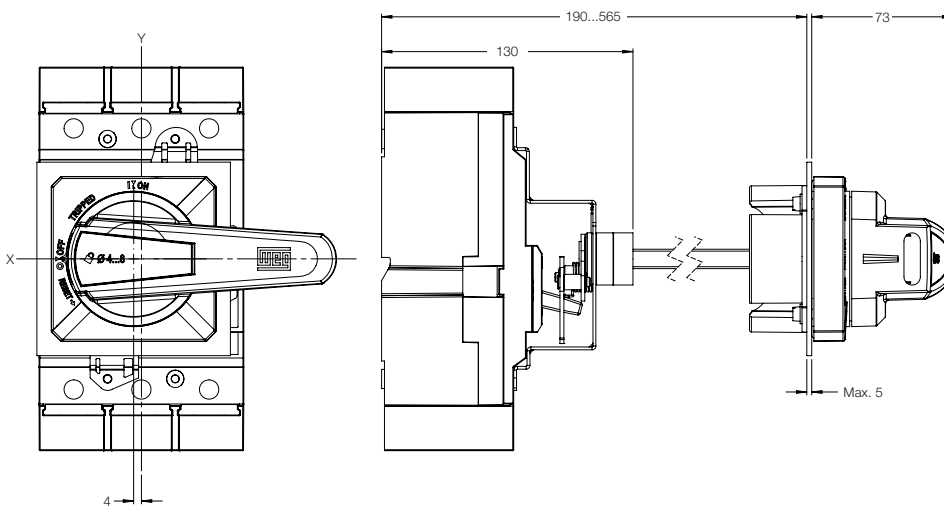

Panel door cutout

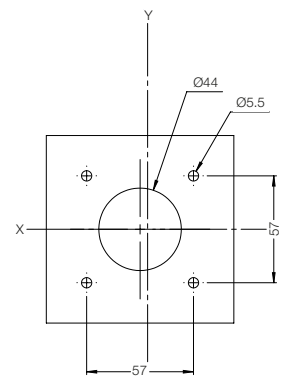

Note: dimensions in millimeters.

Dimensions

Accessories

MRXL - panel door operating handle

Frame 160 3P/4P + MRXL DWB160 (L version)

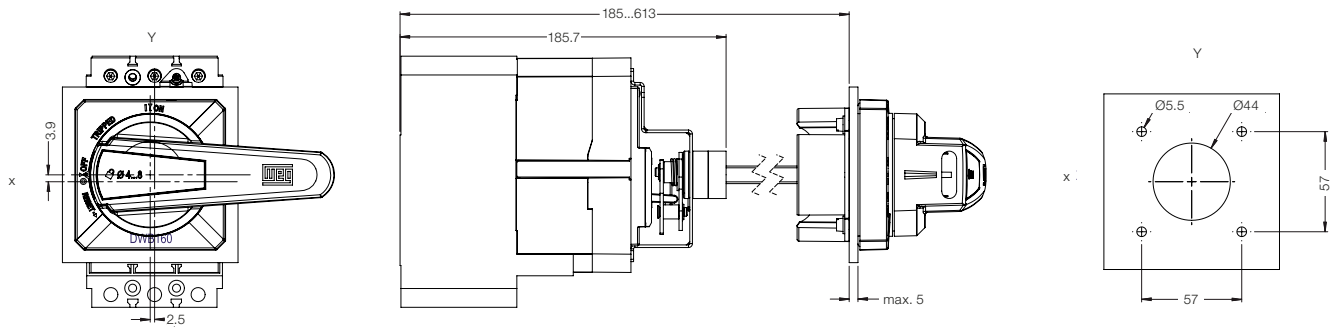

Frame 250 3P/4P + MRXL DWB250 (L version)

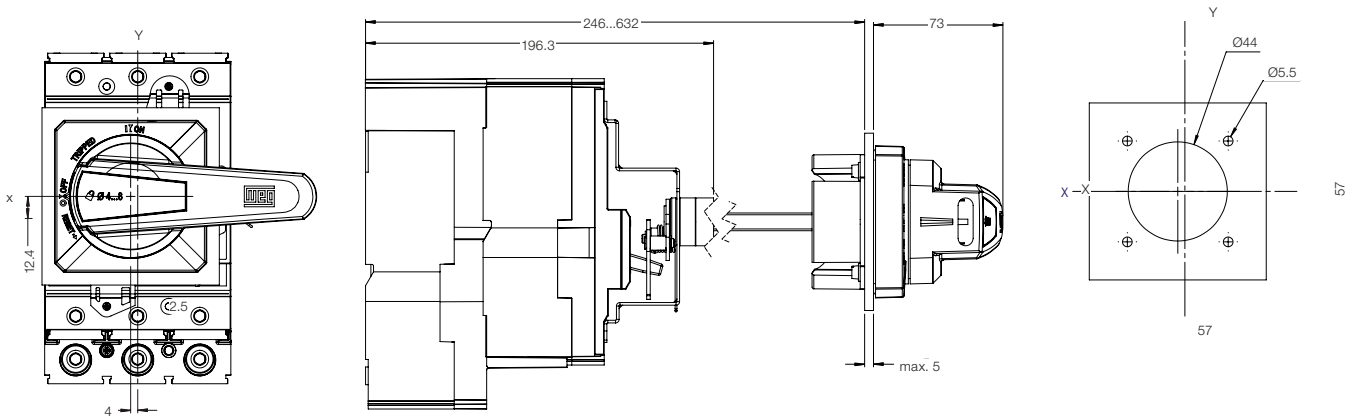

Note: dimensions in millimeters.

Dimensions

Accessories

MRXL - panel door operating handle

Frame 400 3P/4P + MRXL DWB400

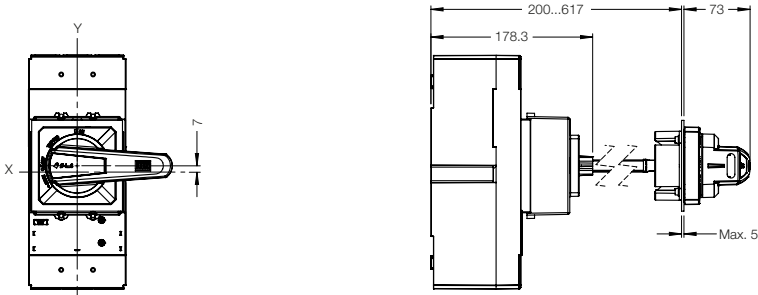

Panel door cutout

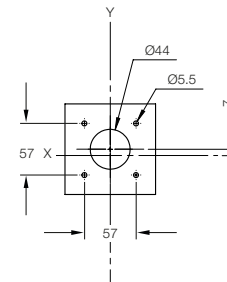

Frame DWB800-1000 + MRXL DWB800-1000

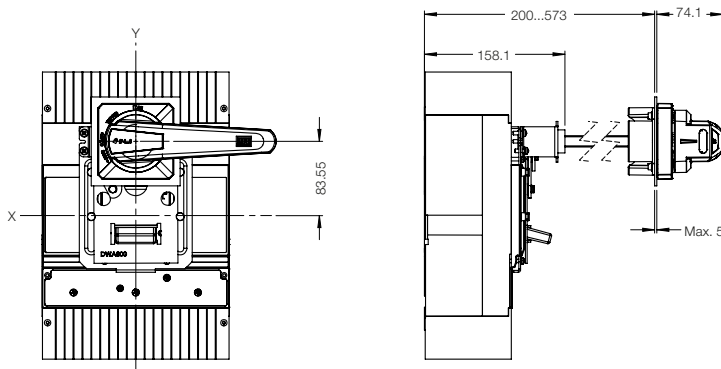

Panel door cutout

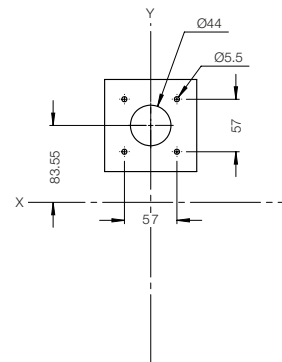

Frame 1600 3P/4P + MRXL DWB1600

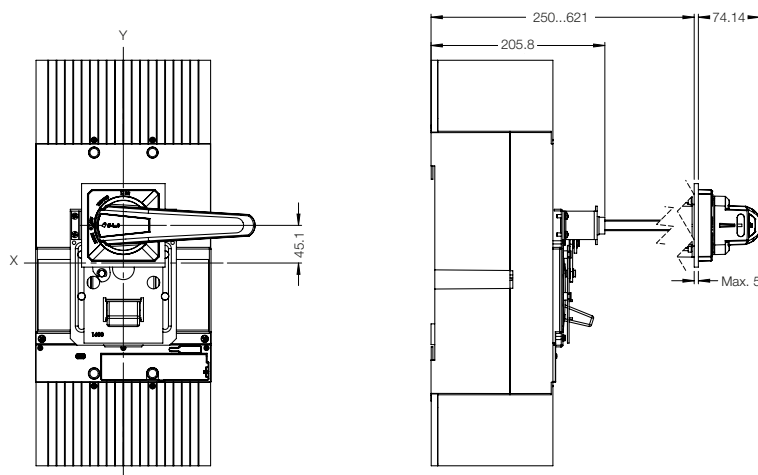

Panel door cutout

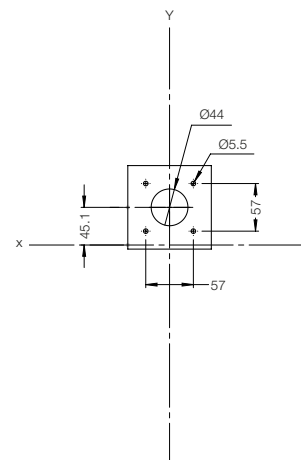

Note: dimensions in millimeters.

Dimensions

Accessories

MRI - internal rotary handle

Frame 400 3P + MRI DWB400

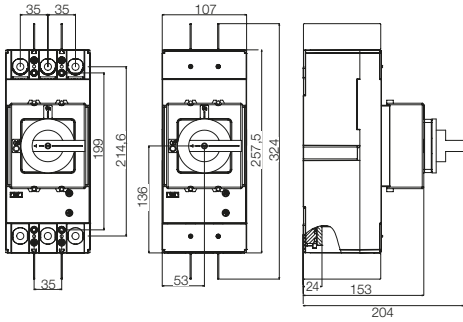

Frame 800-1000 3P + MRI DWB800-1000

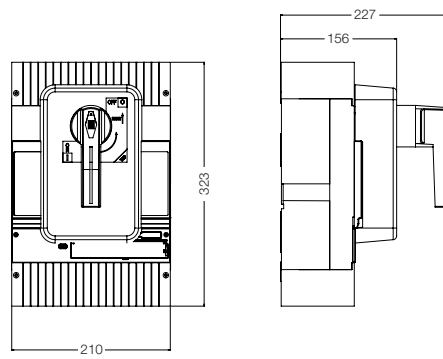

Frame 1600 3P + MRI DWB1600

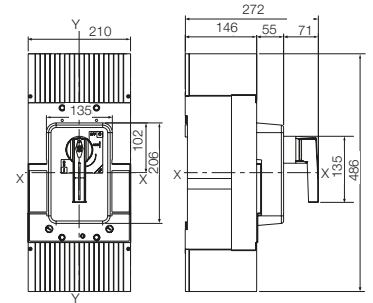

BLIM - mechanical interlock

Frame 160 3P + BLIM DWB160 3P

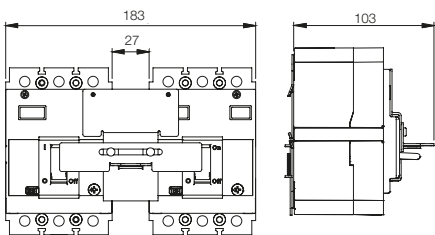

Frame 250 3P + BLIM DWB250 3P

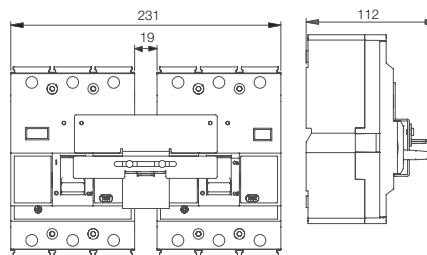

Frame 400 3P + BLIM DWB400 3P

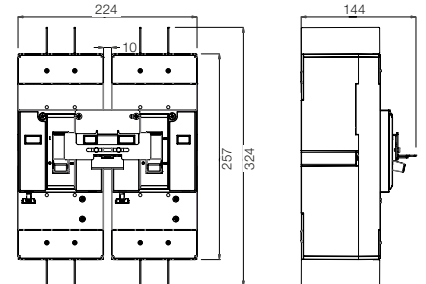

Frame 800 3P + BLIM DWB800 / DWB1000

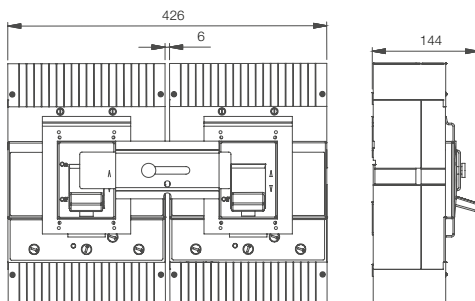

Frame 1600 3P + BLIM DWB1600

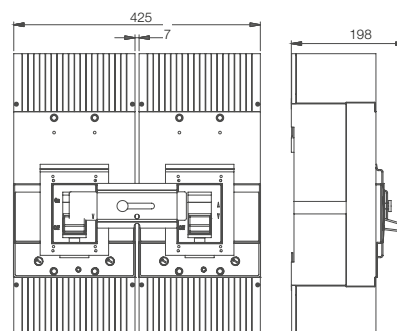

Note: dimensions in millimeters.

Note: dimensions in millimeters.

Dimensions

Accessories

PL - padlocking device

Frame 160 3P + PL DWB160 3P

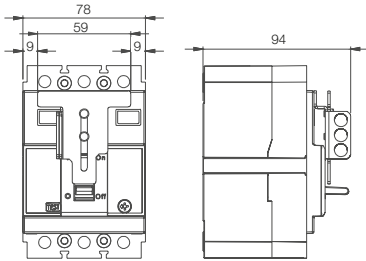

Frame 250 3P + PL DWB250

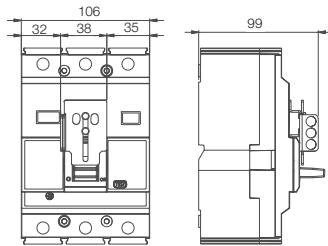

Frame 400 3P + PL DWB400

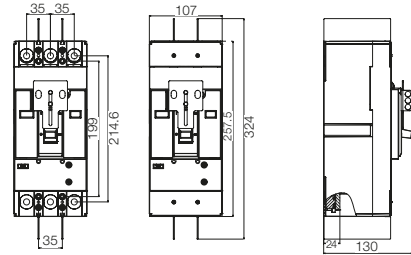

Frame 800-1000 + PL800-1000

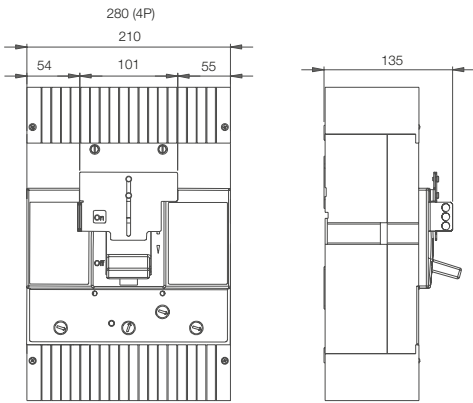

Frame 1600 + PL1600

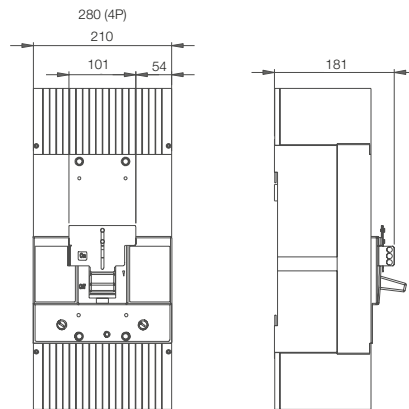

AM - motor operator

DWB400 3P + AM DWB400

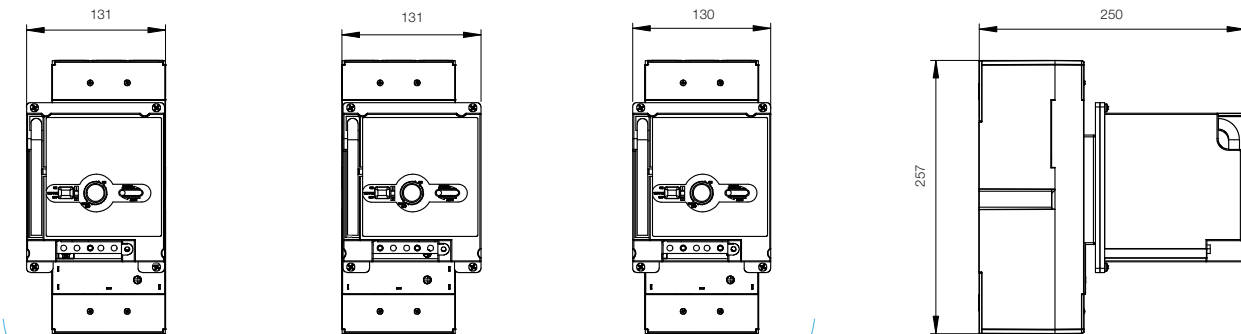

Available mounting positions

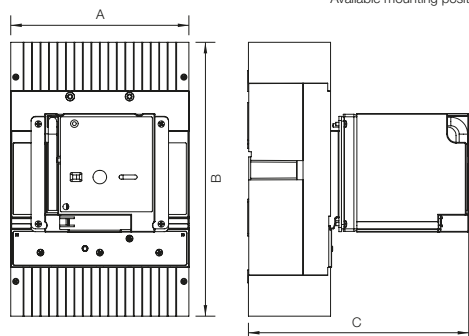

	A	B	C
DWB800 / DWB1000 3P	210 8.27	323 12.72	260 10.23
DWB800 / DWB1000 4P	280 11.02		
DWB1600 3P	210 8.27	486 19.13	309 12.16
DWB1600 4P	280 11.02		

Note: dimensions in millimeters and inches.

Dimensions

Accessories

CTM – mechanical changeover

CTM – DWB400 – 3P

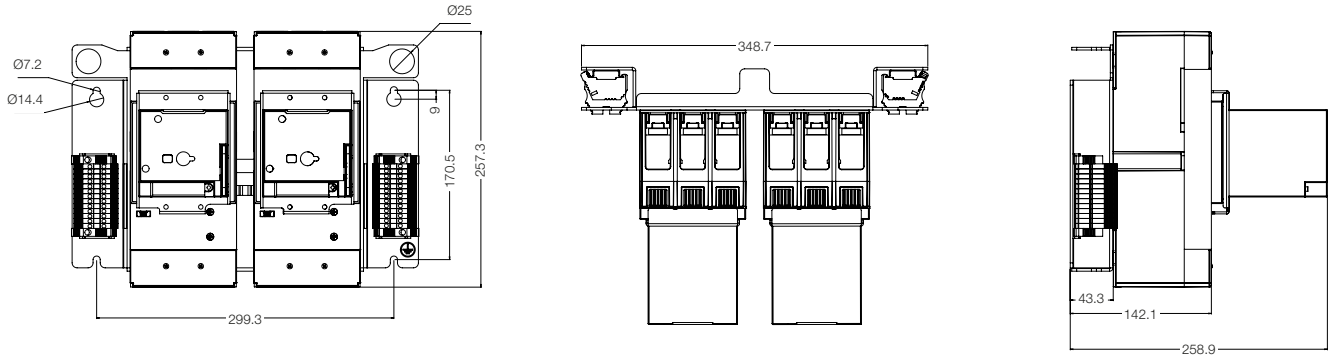

CTM – DWB400 – 4P

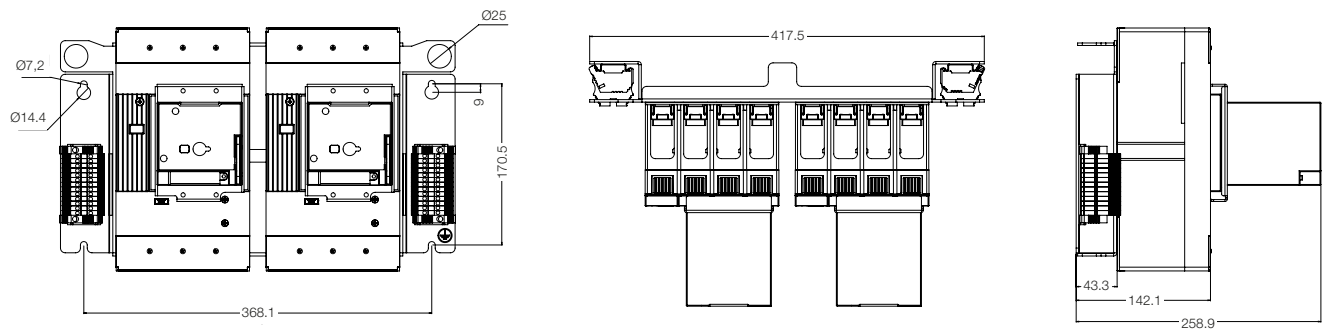

CTM – 1000 - 3P (for DWB800 and DWB1000)

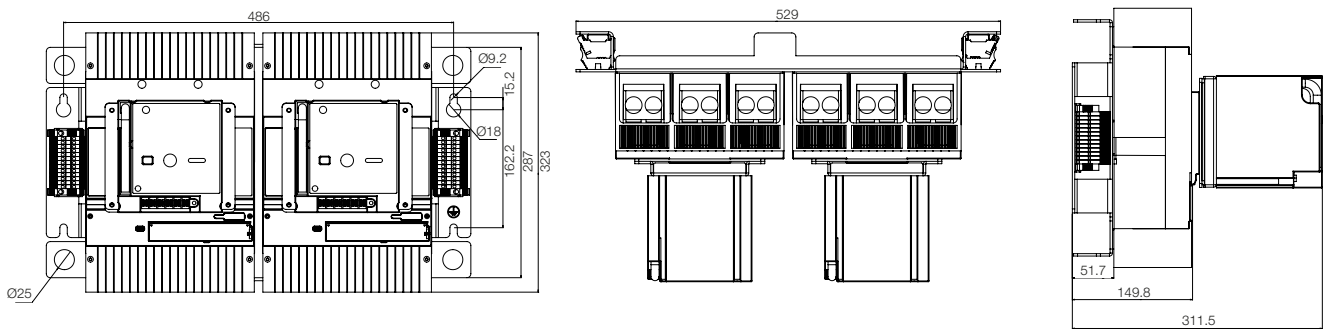

CTM – 1000-4P (for DWB800 and DWB1000)

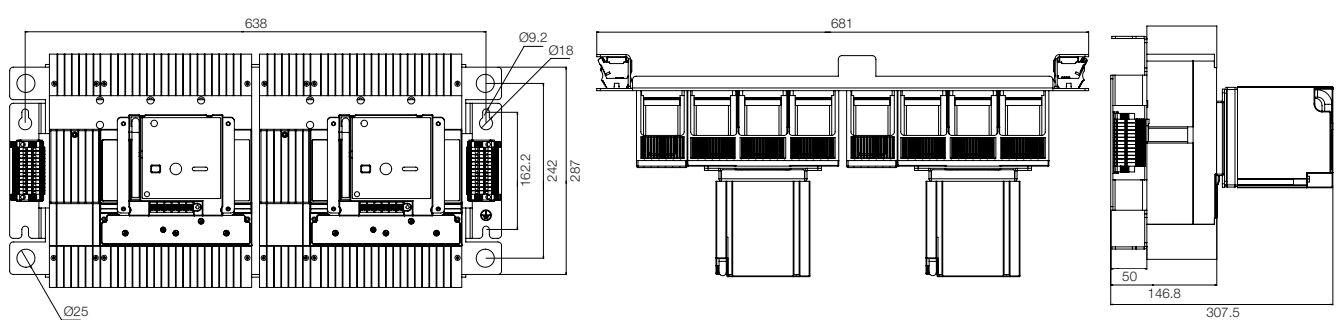

Note: dimensions in millimeters.

Dimensions

Accessories

CTM – mechanical changeover

CTM – 1600-3P (for DWB1600)

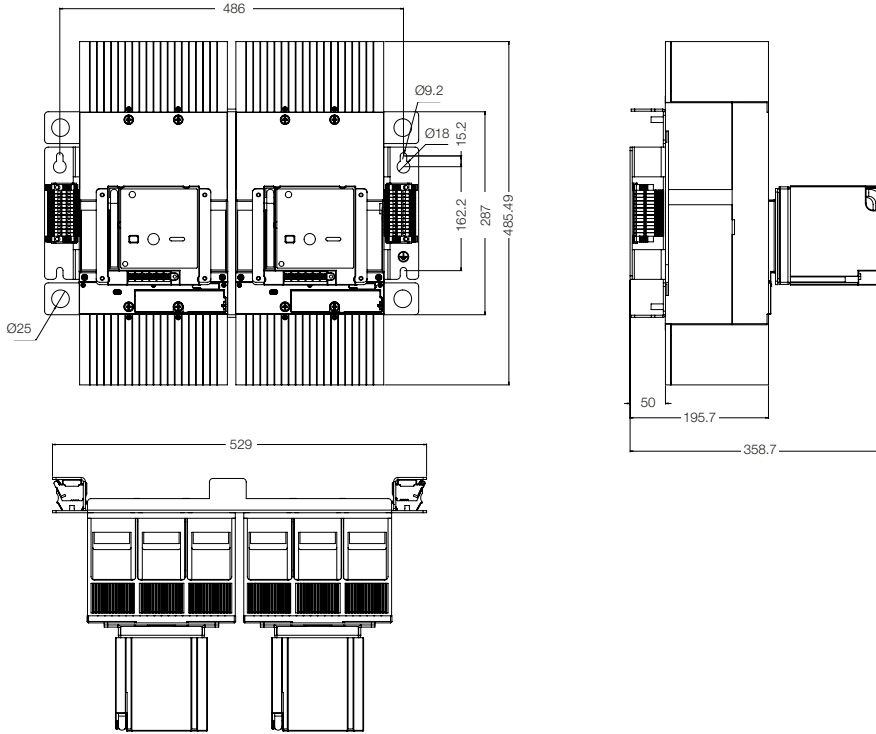

CTM – 1600-4P (for DWB1600)

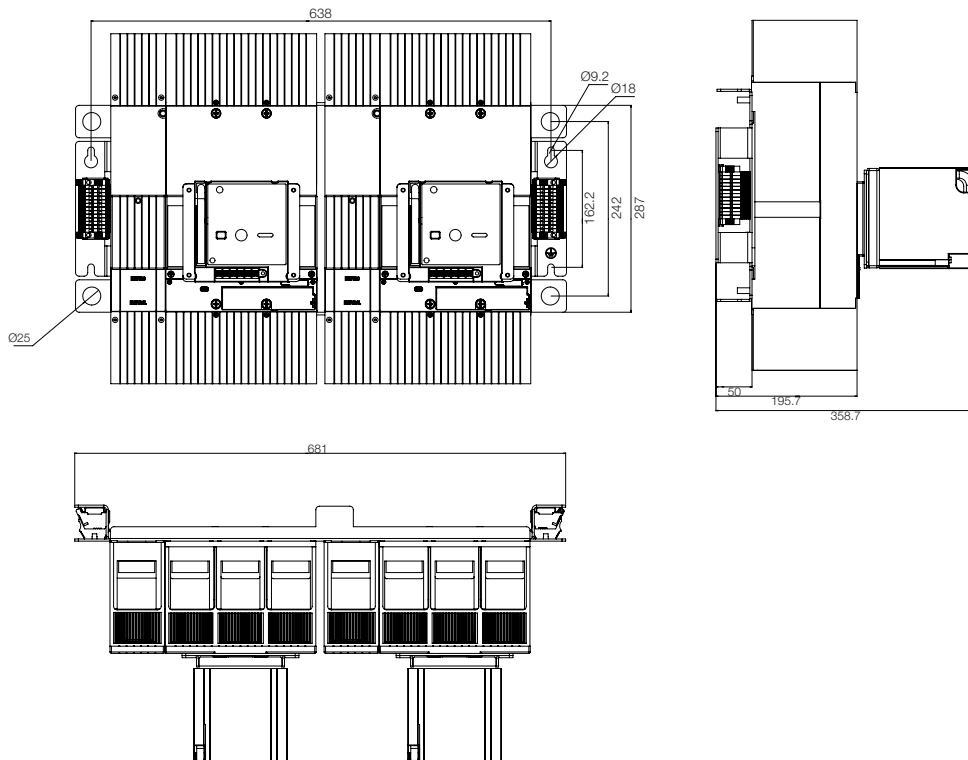

Note: dimensions in millimeters.

Dimensions

Accessories

Protection cover + DWB160 + CT DWB160

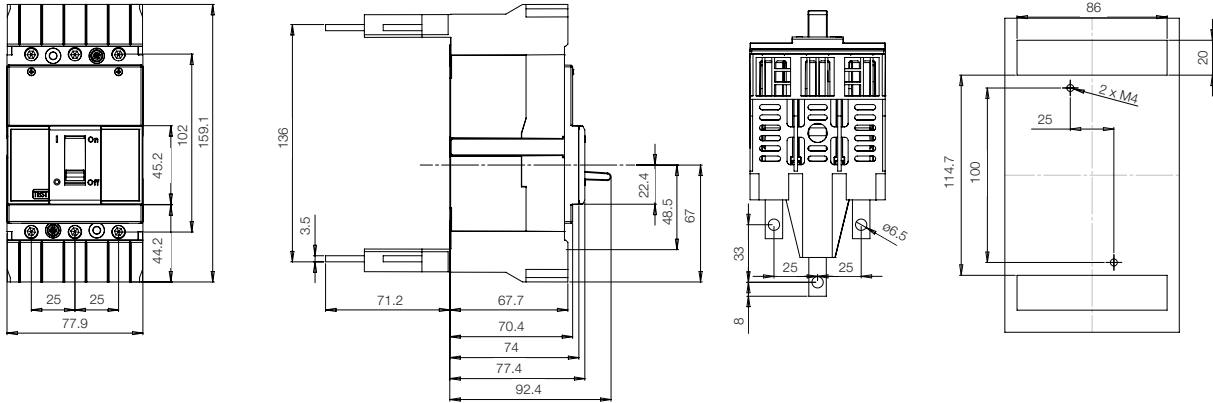

Protection cover + DWB250 + CT DWB250

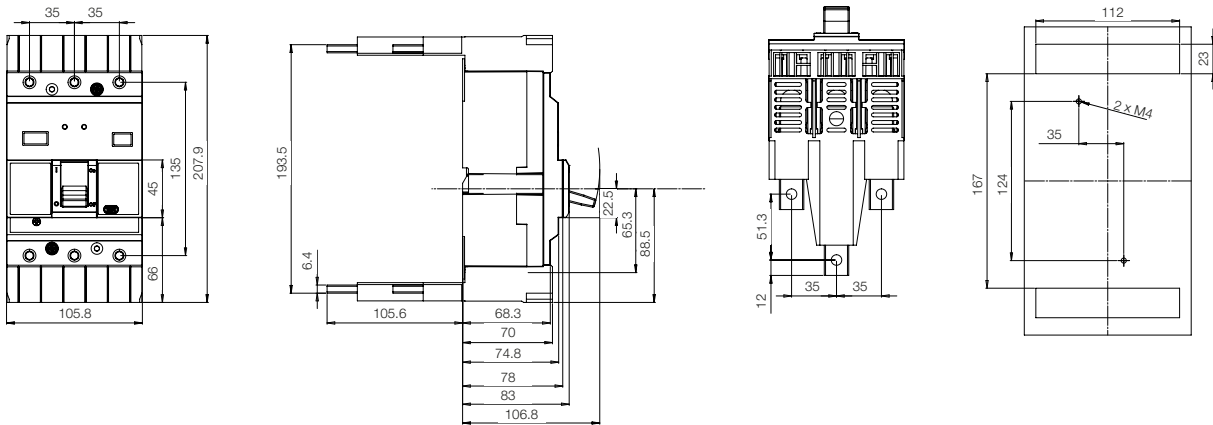

Protection cover + DWB400 + CT DWB400

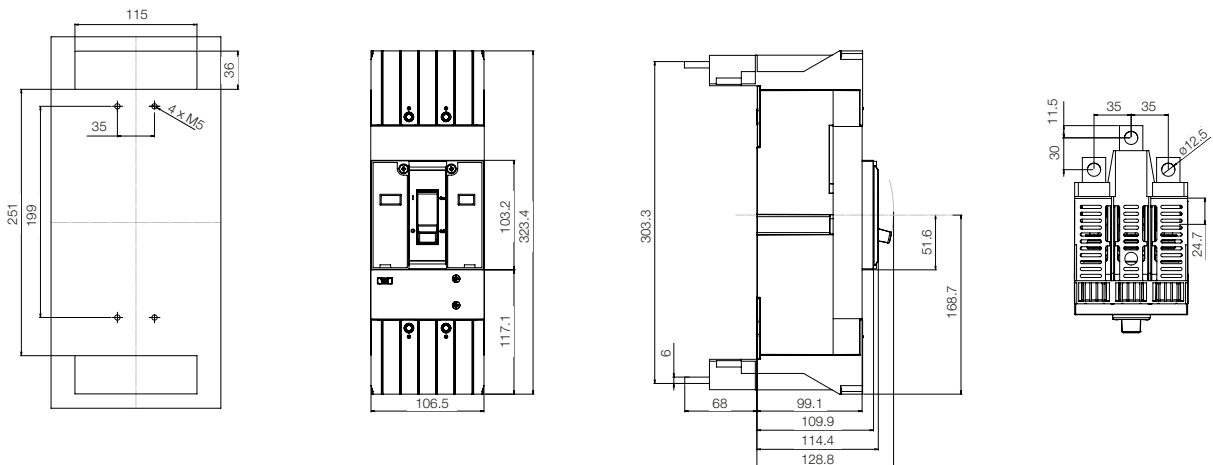

Note: dimensions in millimeters.

Dimensions

Accessories

Protection cover + DWB800 / DWB1000 + CT DWB800 / DWB1000

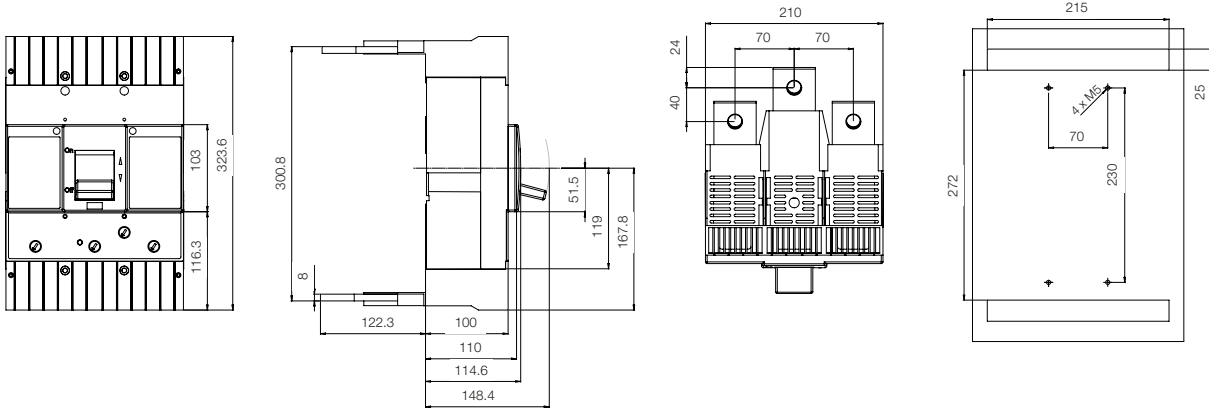

Protection cover + DWB1600 + CT DWB1600

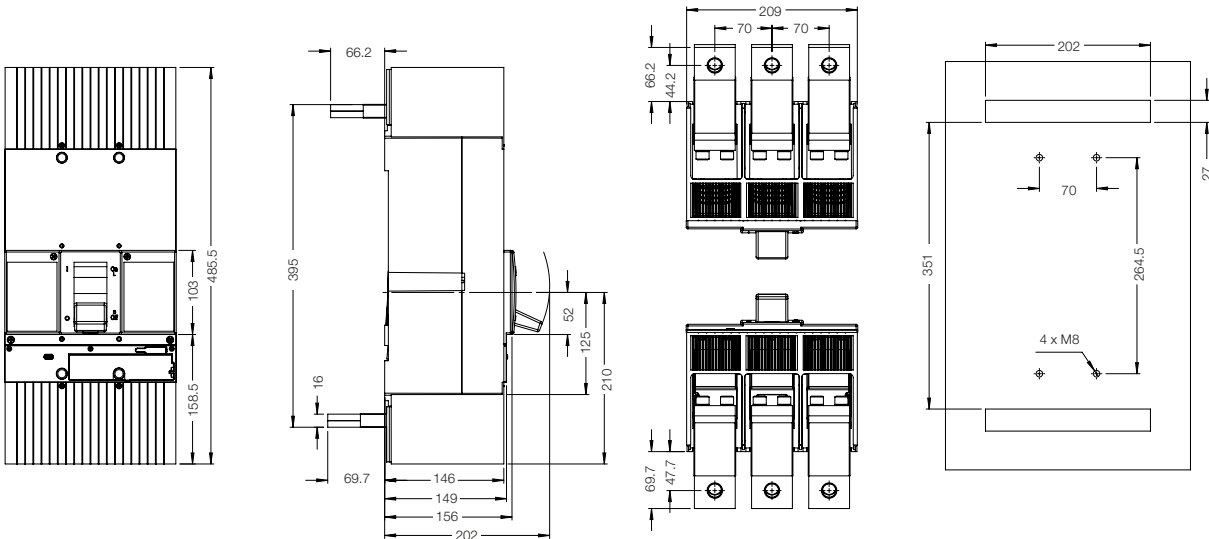

Note: dimensions in millimeters.

Circuit breaker list - reference and code

Distribution

Fixed thermal and fixed magnetic release

Reference ¹⁾	I _n ²⁾	I _m ³⁾	B (18 kA @ 380 V)				N (30 kA @ 380 V) ⁴⁾			L (80 kA @ 380 V)		
			2 poles	3 poles	4 poles (N without protection)	4 poles (N protected) ⁵⁾	3 poles	4 poles (N without protection)	4 poles (N protected) ⁵⁾	3 poles		
DWB160	DWB160_16-DX	16	300	11987784	11339625	12318372	12318469	11339663	12318568	12318659	11339721	
	DWB160_20-DX	20	300	11987786	11339626	12318373	12318470	11339664	12318569	12318660	11339722	
	DWB160_25-DX	25	300	11987787	11339627	12318374	12318472	11339665	12318570	12318661	11339723	
	DWB160_32-DX	32	320	11987858	11339638	12318375	12318473	11339667	12318571	12318663	11339724	
	DWB160_40-DX	40	400	11987860	11339640	12318376	12318474	11339698	12318572	12318664	11339725	
	DWB160_50-DX	50	500	11987861	11339641	12318377	12318475	11339699	12318573	12318665	11339726	
	DWB160_63-DX	63	630	11987862	11339642	12318458	12318476	11339700	12318574	12318666	11339727	
	DWB160_70-DX	70	700	11987863	11339643	12318459	12318488	11339701	12318575	12318667	11339748	
	DWB160_80-DX	80	800	11987864	11339644	12318460	12318489	11339702	12318577	12318698	11339749	
	DWB160_90-DX	90	900	11987865	11339645	12318461	12318490	11339703	12318631	12318699	11339750	
	DWB160_100-DX	100	1,000	11987866	11322258	12318462	12318491	11339704	12318632	12318701	11339751	
	DWB160_110-DX	110	1,100	11987867	11339646	12318463	12318492	11339705	12318633	12318702	11339753	
	DWB160_125-DX	125	1,100	11987878	11339647	12318464	12318493	11339706	12318634	12318703	11339754	
	DWB160_150-DX	150	1,100	11987879	11339658	12318465	12318494	11339707	12318635	12318704	-	
DWB160_160-DX	160	1,100	11987881	11339659	12318466	12318495	11339718	12318636	12318705	-		

Adjustable thermal and fixed magnetic release

Reference ¹⁾	I _n ²⁾	I _m ³⁾	B (18 kA @ 380 V)			N (30 kA @ 380 V)				
			2 poles	3 poles	4 poles (N without protection)	4 poles (N protected) ⁴⁾	3 poles	4 poles (N without protection)	4 poles (N protected) ⁴⁾	
DWB160	DWB160_40-DF	32...40	400	-	11631355	12318002	12318132	11631362	12318160	12318227
	DWB160_50-DF	40...50	500	-	11631358	12318003	12318135	11631363	12318161	12318238
	DWB160_63-DF	50...63	630	-	11631361	12318005	12318136	11631365	12318162	12318240
	DWB160_80-DF	64...80	800	-	11631364	12318007	12318138	11631366	12318163	12318242
	DWB160_100-DF	80...100	1,000	-	11631367	12318008	12318142	11631378	12318164	12318243
	DWB160_125-DF	100...125	1,100	-	11631380	12318009	12318143	11631379	12318221	12318246
DWB160_160-DF	128...160	1,100	-	11631383	12318010	12318144	11631381	12318222	12318247	

Reference ¹⁾	I _n ²⁾	I _m ³⁾	B (18 kA @ 380 V)				N (36 kA @ 380 V)			L (80 kA)		
			2 Poles	3 Poles	4 poles (N without protection)	4 Poles (N protected) ⁴⁾	2 Poles	3 Poles	4 poles (N without protection)	4 Poles (N protected) ⁴⁾	3 Poles	
DWB250	DWB250_100-DF	80...100	1,000	11988406	11339768	12318906	12318954	11988521	11339775	12319489	12319508	11339801
	DWB250_125-DF	100...125	1,250	11988407	11339769	12318907	12318955	11988522	11339776	12319490	12319509	11339802
	DWB250_160-DF	125...160	1,600	11988518	11339770	12318948	12318956	11988524	11339777	12319491	12319510	11339803
	DWB250_200-DF	160...200	2,000	11988519	11339772	12318949	12318957	11988525	11339798	12319492	12319511	11339804
	DWB250_250-DF	200...250	2,500	11988520	11339773	12318950	12318958	11985249	11339799	12319493	12319512	-

Adjustable thermal and adjustable magnetic release

Reference ¹⁾	I _n ²⁾	I _m ³⁾	N (35 kA @ 380 V)			H (65 kA @ 380 V)			
			2 Poles	3 Poles	4 poles (N without protection)	2 Poles	3 Poles	4 poles (N without protection)	
DWB400	DWB400_200-DA	160...200	2,000	12534086	12534150	12534010	12534102	12534122	12534068
	DWB400_250-DA	200...250	2,500	12534085	12534149	12534011	12534101	12534121	12534069
	DWB400_320-DA	250...320	3,200	12534084	12534148	12534012	12534100	12534120	12534070
	DWB400_400-DA	320...400	4,000	12534083	12534127	12534013	12534099	12534106	12534071

Reference ¹⁾	I _n ²⁾	I _m ³⁾	S (50 kA @ 380 V)			H (65 kA @ 380 V)			
			2 Poles	3 Poles	4 poles (N without protection)	2 Poles	3 Poles	4 poles (N without protection)	
DWB800	DWB800_320-DA	225-320	3,200	-	13467830	13467882	--	13467899	13467960
	DWB800_400-DA	280-400	4,000	-	13467831	13467883	--	13467902	13467961
	DWB800_500-DA	350-500	5,000	-	13467833	13467885	--	13467904	13467962
	DWB800_630-DA	440-630	6,300	-	13467879	13467886	--	13467905	13467963
	DWB800_800-DA	560-800	8,000	-	13467880	13467887	--	13467906	13467964

Electronic release - LSI

Reference ¹⁾	I _n ²⁾	I _m ³⁾	S (50 kA @ 380 V)				H (65 kA @ 380 V)			
			2 Poles	3 Poles	4 poles (N without protection)	4 Poles (N protected) ⁵⁾	3 Poles	4 poles (N without protection)	4 Poles (N protected) ⁵⁾	
DWB1000	DWB1000_500-3ET	200-500	6,000	-	13468912	13468916	14154953	13468930	13468936	14154952
	DWB1000_630-3ET	250-630	7,560	-	13468913	13468917	14154951	13468931	13468937	14154950
	DWB1000_800-3ET	320-800	9,600	-	13468914	13468928	14154948	13468932	13468968	14154897
	DWB1000_1000-3ET	400-1,000	12,000	-	13468915	13468929	14048446	13468934	13468969	14154895

DWB1600	DWB1600_-1250-3E	500-1,250	15,000	-	13789708	13789711	14154990			
	DWB1600_1600-3E	640-1,600	19,200	-	13789710	13789712	14154991			

- Notes: 1) Fill in the spaces () with the letter equivalent to the breaking capacity and the number of poles of the circuit-breaker according to the table.
 2) I_n = nominal current.
 3) I_m = magnetic trigger current (maximum value).
 4) For total neutral protection (N) without setting add the letter "T" at the end of the encoding of the circuit-breaker.
 5) For total neutral protection (N) adjustable add the letter "A" at the end of the encoding of the circuit-breaker.
 6) For I_n ≤ 32A: I_{cu} = 20 kA @ 380/415 V.

Circuit breaker list - reference and code

Generator

Fixed thermal and fixed magnetic release

Reference ¹⁾		$I_n^{2)}$	$I_m^{3)}$	B (18 kA @ 380 V)	
				3 poles	
DWB160	DWB160B55-3GX	55	300	11340061	
	DWB160B75-3GX	75	375	11340062	
	DWB160B85-3GX	85	425	11340063	
	DWB160B105-3GX	105	525	11340064	
	DWB160B125-3GX	125	625	11340066	
	DWB160B140-3GX	140	700	11340067	
DWB160B160-3GX	160	800	11340068		

Adjustable thermal and fixed magnetic release

reference ¹⁾		$I_n^{2)}$	$I_m^{3)}$	3 poles	B (18kA@380V)	
					4 Poles (N without protection)	
DWB160	DWB160B55-4GF	44...55	275	-	15354990	
	DWB160B75-4GF	60...75	375	-	15354991	
	DWB160B85-4GF	68...85	425	-	15354992	
	DWB160B105-4GF	84...105	525	-	15354993	
	DWB160B125-4GF	100...125	625	-	15354994	
	DWB160B140-4GF	112...140	700	-	15354995	
	DWB160B160-4GF	128...160	800	-	14146408	

Adjustable thermal and fixed magnetic release

Reference ¹⁾		$I_n^{2)}$	$I_m^{3)}$	B (18 kA @ 380 V)	
				3 poles	4 poles
DWB250	DWB250_105-_GF	80...105	525	11340071	15354996
	DWB250_125-_GF	100...125	625	11340072	15354997
	DWB250_160-_GF	125...160	800	11340073	15355018
	DWB250_200-_GF	160...200	1,000	11340074	15355019
	DWB250_250-_GF	200...250	1,250	11340075	14146410

Adjustable thermal and adjustable magnetic release

Reference ¹⁾		$I_n^{2)}$	$I_m^{3)}$	N (35 kA @ 380 V)	
				3 poles	4 poles (N without protection)
DWB400	DWB400N200-_GA	160...200	1,000	12534082	12531407
	DWB400N250-_GA	200...250	1,250	12534079	12530983
	DWB400N320-_GA	250...320	1,600	12534078	12533771
	DWB400N400-_GA	320...400	2,000	12534077	12533775
DWB800	DWB800N320-_GA	225-320	1,600	13467967	-
	DWB800N400-_GA	280-400	2,000	13467988	-
	DWB800N500-_GA	350-500	2,500	13467989	-
	DWB800N630-_GA	440-630	3,150	13467991	14146411
	DWB800N800-_GA	560-800	4,000	13467992	14146416

Electronic release - LSI

Reference ¹⁾		$I_n^{2)}$	$I_m^{3)}$	S (50 kA @ 380 V)			
				2 poles	3 poles	4 poles (N without protection)	4 poles (N adjustable) ⁵⁾
DWB1000	DWB1000S500-_ET	200-500	1,000-6,000	-	13468912	13468916	14154953
	DWB1000S630-_ET	250-630	1,250-7,500	-	13468913	13468917	14154951
	DWB1000S800-_ET	320-800	1,600-9,600	-	13468914	13468928	14154948
	DWB1000S1000-_ET	400-1,000	2,000-12,000	-	13468915	13468929	14048446
DWB1600	DWB1600_1250-3E_	500-1,250	15,000	-	13789708	13789711	14154990
	DWB1600_1600-3E_	640-1,600	19,200	-	13789710	13789712	14154991

Notes: 1) Fill in the spaces (_) with the letter equivalent to the breaking capacity and the number of poles of the circuit-breaker according to the table.

2) I_n = nominal current.

3) I_m = magnetic trigger current (maximum value).

Circuit breaker list - reference and code

Motor

Fixed magnetic release

Reference ¹⁾		$I_n^{2)}$	$I_m^{3)}$	N (30 kA @ 380 V) ⁴⁾	L (80 kA @ 380V)
				3 poles	3 poles
DWB160	DWB160_25-3MF	25	300	11339864	11339936
	DWB160_32-3MF	32	384	11339865	11339937
	DWB160_40-3MF	40	480	11339866	11339948
	DWB160_50-3MF	50	600	11339867	11339950
	DWB160_65-3MF	65	780	11339928	11339951
	DWB160_80-3MF	80	960	11339929	11339952
	DWB160_95-3MF	95	1,140	11339930	11339953

Reference ¹⁾		I_n	I_m	N (35 kA @ 380 V)	L (80 kA @ 380V)
				3 poles	3 poles
DWB250	DWB250_80-3MF	80	960	11340029	11340035
	DWB250_105-3MF	105	1,260	11340031	11340037
	DWB250_150-3MF	150	1,800	11340032	11340058
	DWB250_185-3MF	185	2,220	11340033	11340059
	DWB250_200-3MF	200	2,400	11631304	11631305

Adjustable magnetic release

Reference ¹⁾		$I_n^{2)}$	$I_m^{3)}$	I_{cu} (415 V)
				H (65 kA)
		3 poles		
DWB400	DWB400H150-3MA	150	1,125...2,250	12534076
	DWB400H185-3MA	185	1,400...2,775	12534075
	DWB400H250-3MA	250	1,900...3,750	12534074
	DWB400H320-3MA	320	2,400...4,800	12534073
DWB800	DWB800H420-3MA	420	3,150-6,300	13467997
	DWB800H500-3MA	500	3,750-7,500	13468019
DWB1600	DWB1600N1000-3MA	1.000	3.200-19.200	13469757

Notes: 1) Fill in the spaces (_) with the letter equivalent to the breaking capacity and the number of poles of the circuit-breaker according to the table.

2) I_n = nominal current.

3) I_m = magnetic trigger current (maximum value).

Global presence

is essential, as much as understanding your needs.



Global Presence

With more than 30,000 employees worldwide, WEG is one of the largest electric motors, electronic equipments and systems manufacturers. We are constantly expanding our portfolio of products and services with expertise and market knowledge. We create integrated and customized solutions ranging from innovative products to complete after-sales service.

WEG's know-how guarantees our **molded case circuit breakers DWB** are the right choice for your application and business, assuring safety, efficiency and reliability.



Availability is to have a global support network



Partnership is to create solutions that suits your needs



Competitive edge is to unite technology and innovation





Know More

Full Circuit Breaker Solutions

Dimensions (frames)	Currents (A)	Thermomagnetic Protection	Electronic Protection	Breaking capacity I_{cu} @ 380 V ca
---------------------	--------------	---------------------------	-----------------------	---------------------------------------

MDW Miniature Circuit Breaker

	Frame 1	2 to 63	Fixed	-	3
	Frame 2	70 to 125			

MDWH Miniature Circuit Breaker¹⁾

	Frame 1	6 to 63	Fixed	-	10 ¹⁾
	Frame 2	70 to 125			

DW Molded Case Circuit Breaker

	160	16 to 160	Fixed and adjustable	-	18 - 80
	250	100 to 250			18 - 80
	400	200 to 400			35 - 65
	800/1000	320 to 1000			35 - 65
	1600	1250 to 1600			35

ACW High-Capacity Molded Case Circuit Breaker

	100/160	20 to 160	Fixed and adjustable	-	85 - 150
	101/161/250	16 to 250			85 - 150
	400/630	160 to 400			85 - 150
	800	630 to 800			100

ABW Open Circuit Breaker

	800/1600	320 to 1600	-	Adjustable	65
	2000/2500/3200	800 to 3200			85
	4000/5000	1600 to 5000			100
	6300	2520 to 6300			120

Note: 1) MDWH at 220 V AC $I_{cu} = 20$ kA.

Excelence is to provide a whole solution in industrial automation that improves our customers productivity.

Visit: www.weg.net

 youtube.com/wegvideos

The scope of WEG Group solutions is not limited to products and solutions presented in this catalogue.

To see our portfolio, contact us.

For WEG's worldwide operations visit our website



www.weg.net



 +55 47 3276.4000

 automacao@weg.net

 Jaraguá do Sul - SC - Brazil

Cod: 50070240 | Rev: 07 | Date (m/y): 03/2023.

The values shown are subject to change without prior notice.
The information contained is reference values.